

TEST REPORT

Application No.: SHEM1812001704TX
Applicant: Ningbo Airtac Automatic Industrial Co.,Ltd.
Address of Applicant: No.88, Siming E.RD.,High Tech Area of Fenghua City,Zhejiang,China
Manufacturer: Ningbo Airtac Automatic Industrial Co.,Ltd.
Address of Manufacturer: No.88, Siming E.RD.,High Tech Area of Fenghua City,Zhejiang,China
Factory: Ningbo Airtac Automatic Industrial Co.,Ltd.
Address of Factory: No.88, Siming E.RD.,High Tech Area of Fenghua City,Zhejiang,China
Equipment Under Test (EUT):
EUT Name: Coil
Model No.: CDA116A, CDA116E, CDA116B, CDA116F, CDA116C
Standard(s) : EN 61000-6-3:2007 +A1:2011
 EN 61000-6-1:2007
Date of Receipt: 2018-12-05
Date of Test: 2018-12-07 to 2018-12-15
Date of Issue: 2019-01-07

| | |
|---------------------|--------------|
| Test Result: | Pass* |
|---------------------|--------------|

* In the configuration tested, the EUT complied with the standards specified above.

The CE mark as shown below can be used, under the responsibility of the manufacturer, after completion of an EU Declaration of Conformity and compliance with all relevant EU Directives.

Parlan Zhan

Parlan Zhan
E&E Section Manager





The manufacturer should ensure that all products in series production are in conformity with the product sample detailed in this report. If the product in this report is used in any configuration other than that detailed in the report, the manufacturer must ensure the new system complies with all relevant standards. Any mention of SGS International Electrical Approvals or testing done by SGS International Electrical Approvals in connection with, distribution or use of the product described in this report must be approved by SGS International Electrical Approvals in writing.

Unless otherwise agreed in writing, this document is issued by the Company subject to its General Conditions of Service printed overleaf, available on request or accessible at <http://www.sgs.com/en/Terms-and-Conditions.aspx> and, for electronic format documents, subject to Terms and Conditions for Electronic Documents at <http://www.sgs.com/en/Terms-and-Conditions/Terms-e-Document.aspx>. Attention is drawn to the limitation of liability, indemnification and jurisdiction issues defined therein. Any holder of this document is advised that information contained hereon reflects the Company's findings at the time of its intervention only and within the limits of Client's instructions, if any. The Company's sole responsibility is to its Client and this document does not exonerate parties to a transaction from exercising all their rights and obligations under the transaction documents. This document cannot be reproduced except in full, without prior written approval of the Company. Any unauthorized alteration, forgery or falsification of the content or appearance of this document is unlawful and offenders may be prosecuted to the fullest extent of the law. Unless otherwise stated the results shown in this test report refer only to the sample(s) tested and such sample(s) are retained for 30 days only.
Attention: To check the authenticity of testing /inspection report & certificate, please contact us at telephone: (86-755) 8307 1443, or email: CN.Doccheck@sgs.com





| Revision Record | | | |
|-----------------|-------------|------------|--------|
| Version | Description | Date | Remark |
| 00 | Original | 2019-01-07 | / |
| | | | |
| | | | |

| | | | |
|---------------------------------|--|--|--|
| Authorized for issue by: | | | |
| | |  | |
| | | <hr/> | |
| | | Leo Xu / Project Engineer | |
| | |  | |
| | | <hr/> | |
| | | Bruce Tang / Reviewer | |

2 Test Summary

| Emission Part | | | | |
|---|----------------------------|-------------------|--------------------------|--------|
| Item | Standard | Method | Requirement | Result |
| Conducted Emissions at Mains Terminals (150kHz-30MHz) | EN 61000-6-3:2007 +A1:2011 | CISPR 16-2-1 | N/A | Pass |
| Radiated Emissions (30MHz-1GHz) | EN 61000-6-3:2007 +A1:2011 | CISPR 16-2-3 | N/A | Pass |
| Harmonic Current Emission | EN 61000-6-3:2007 +A1:2011 | EN 61000-3-2:2014 | Class A | N/A* |
| Voltage Fluctuations and Flicker | EN 61000-6-3:2007 +A1:2011 | EN 61000-3-3:2013 | Clause 5 of EN 61000-3-3 | Pass |

N/A: Not applicable

N/A*: Please refer to Section 6.3 of this report for details.

| Immunity Part | | | | |
|---|-------------------|------------------------------------|--|--------|
| Item | Standard | Method | Requirement | Result |
| Electrostatic Discharge | EN 61000-6-1:2007 | EN 61000-4-2:2009 | 4kV Contact Discharge 8kV Air Discharge | Pass |
| Radiated Immunity(80MHz-2.7GHz) | EN 61000-6-1:2007 | EN 61000-4-3:2006 +A1:2008+A2:2010 | 3V/m, 80%, 1kHz Amp. Mod. 3V/m, 80%, 1kHz Amp. Mod. 1V/m, 80%, 1kHz Amp. Mod. | Pass |
| Electrical Fast Transients/Burst at Power Port | EN 61000-6-1:2007 | EN 61000-4-4:2012 | 1kV 5/50ns Tr/Td 5kHz Repetition Frequency | Pass |
| Surge at Power Port | EN 61000-6-1:2007 | EN 61000-4-5:2014 +A1:2017 | 1.2/50µs Tr/Td 0.5kV Line to Line 0.5kV Line to Ground | Pass |
| Conducted Immunity at Power Port (150kHz-80MHz) | EN 61000-6-1:2007 | EN 61000-4-6:2014 | 3Vrms (emf),80%,1kHz Amp. Mod. | Pass |
| Power Frequency Magnetic Field | EN 61000-6-1:2007 | EN 61000-4-8:2010 | 50Hz 3A/m | Pass |
| Voltage Dips and Interruptions | EN 61000-6-1:2007 | EN 61000-4-11:2004 +A1:2017 | 0 % UT for 0.5per 0 % UT for 1per 70 % UT for 25per 0 % UT for 250per UT is Supply Voltage | Pass |

N/A: Not applicable

3 Contents

| | Page |
|--|-----------|
| 1 COVER PAGE..... | 1 |
| 2 TEST SUMMARY | 3 |
| 3 CONTENTS..... | 4 |
| 4 GENERAL INFORMATION..... | 5 |
| 4.1 DETAILS OF E.U.T. | 5 |
| 4.2 DESCRIPTION OF SUPPORT UNITS | 5 |
| 4.3 MEASUREMENT UNCERTAINTY..... | 5 |
| 4.4 TEST LOCATION..... | 6 |
| 4.5 TEST FACILITY..... | 6 |
| 4.6 DEVIATION FROM STANDARDS..... | 6 |
| 4.7 ABNORMALITIES FROM STANDARD CONDITIONS..... | 6 |
| 4.8 MONITORING OF EUT FOR ALL IMMUNITY TEST | 6 |
| 5 EQUIPMENT LIST | 7 |
| 6 EMISSION TEST RESULTS..... | 9 |
| 6.1 CONDUCTED EMISSIONS AT MAINS TERMINALS (150kHz-30MHz) | 9 |
| 6.2 RADIATED EMISSIONS (30MHz-1GHz) | 20 |
| 6.3 HARMONIC CURRENT EMISSION | 31 |
| 6.4 VOLTAGE FLUCTUATIONS AND FLICKER | 32 |
| 7 IMMUNITY TEST RESULTS..... | 34 |
| 7.1 PERFORMANCE CRITERIA DESCRIPTION IN EN 61000-6-1:2007 | 34 |
| 7.2 ELECTROSTATIC DISCHARGE | 35 |
| 7.3 RADIATED IMMUNITY(80MHz-2.7GHz) | 36 |
| 7.4 ELECTRICAL FAST TRANSIENTS/BURST AT POWER PORT | 38 |
| 7.5 SURGE AT POWER PORT | 39 |
| 7.6 CONDUCTED IMMUNITY AT POWER PORT (150kHz-80MHz)..... | 41 |
| 7.7 POWER FREQUENCY MAGNETIC FIELD | 42 |
| 7.8 VOLTAGE DIPS AND INTERRUPTIONS | 43 |
| 8 PHOTOGRAPHS..... | 44 |
| 8.1 CONDUCTED EMISSIONS AT MAINS TERMINALS (150kHz-30MHz) TEST SETUP | 44 |
| 8.2 RADIATED EMISSIONS (30MHz-1GHz) TEST SETUP..... | 46 |
| 8.3 VOLTAGE FLUCTUATIONS AND FLICKER TEST SETUP | 49 |
| 8.4 ELECTROSTATIC DISCHARGE TEST SETUP..... | 51 |
| 8.5 RADIATED IMMUNITY(80MHz-2.7GHz) TEST SETUP..... | 54 |
| 8.6 ELECTRICAL FAST TRANSIENTS/BURST AT POWER PORT TEST SETUP | 56 |
| 8.7 SURGE AT POWER PORT TEST SETUP..... | 59 |
| 8.8 CONDUCTED IMMUNITY AT POWER PORT (150kHz-80MHz) TEST SETUP..... | 61 |
| 8.9 POWER FREQUENCY MAGNETIC FIELD TEST SETUP | 64 |
| 8.10 VOLTAGE DIPS AND INTERRUPTIONS TEST SETUP | 66 |
| 8.11 EUT CONSTRUCTIONAL DETAILS (EUT PHOTOS)..... | 69-73 |

4 General Information

4.1 Details of E.U.T.

Power supply: CDA116A:AC220V
CDA116E:AC24V
CDA116B:DC24V
CDA116F:DC12V
CDA116C:AC110V

4.2 Description of Support Units

| Description | Manufacturer | Model No. | Serial No. |
|-----------------|-----------------------------|-----------|------------|
| DC power supply | MCH | MCH-303A | |
| Power Supply | Fengguan motor (Kunshan) | 86A245000 | |

4.3 Measurement Uncertainty

| No. | Item | Measurement Uncertainty |
|-----|---|---------------------------|
| 1 | Conducted Emission at mains port using AMN | ±3.2dB (9kHz to 150kHz) |
| | | ±3.0dB (150kHz to 30MHz) |
| 2 | Conducted Emission at mains port using VP | ±1.9 dB (9kHz to 30MHz) |
| 3 | Conducted Emission at telecommunication port using AAN | ±2.4 dB (150kHz to 30MHz) |
| 4 | Radiated Power | ±3.5dB |
| 5 | Radiated emission | ±4.4dB (30MHz-1GHz) |
| | | ±4.6dB (1GHz-6GHz) |

Note: The measurement uncertainty represents an expanded uncertainty expressed at approximately the 95% confidence level using a coverage factor of k=2.

4.4 Test Location

All tests were performed at:

SGS-CSTC Standards Technical Services (Shanghai) Co., Ltd. E&E Lab
588 West Jindu Road, Xinqiao, Songjiang, 201612 Shanghai, China
Tel: +86 21 6191 5666 Fax: +86 21 6191 5678

No tests were sub-contracted.

4.5 Test Facility

The test facility is recognized, certified, or accredited by the following organizations:

- **CNAS (No. CNAS L0599)**

CNAS has accredited SGS-CSTC Standards Technical Services (Shanghai) Co., Ltd. to ISO/IEC 17025:2005 General Requirements for the Competence of Testing and Calibration Laboratories (CNAS-CL01 Accreditation Criteria for the Competence of Testing and Calibration Laboratories) for the competence in the field of testing.

- **NVLAP (Certificate No. 201034-0)**

SGS-CSTC Standards Technical Services (Shanghai) Co., Ltd. is accredited by the National Voluntary Laboratory Accreditation Program (NVLAP). Certificate No. 201034-0.

- **FCC –Designation Number: CN5033**

SGS-CSTC Standards Technical Services (Shanghai) Co., Ltd. has been recognized as an accredited testing laboratory.

Designation Number: CN5033. Test Firm Registration Number: 479755.

- **Industry Canada (IC) – IC Assigned Code: 8617A**

The 3m Semi-anechoic chamber of SGS-CSTC Standards Technical Services (Shanghai) Co., Ltd. has been registered by Certification and Engineering Bureau of Industry Canada for radio equipment testing with Registration No.: 8617A-1.

- **VCCI (Member No.: 3061)**

The 3m Semi-anechoic chamber and Shielded Room of SGS-CSTC Standards Technical Services (Shanghai) Co., Ltd. has been registered in accordance with the Regulations for Voluntary Control Measures with Registration No.: R-13868, C-14336, T-12221, G-10830 respectively.

4.6 Deviation from Standards

None

4.7 Abnormalities from Standard Conditions

None

4.8 Monitoring of EUT for All Immunity Test

Visual: working status

5 Equipment List

| Conducted Emissions at Mains Terminals (150kHz-30MHz) | | | | | |
|--|---------------------|-----------------|---------------------|-----------------|---------------------|
| Equipment | Manufacturer | Model No | Inventory No | Cal Date | Cal Due Date |
| EMI test receiver | Rohde & Schwarz | ESR7 | SHEM162-1 | 2017-12-20 | 2018-12-19 |
| Line impedance stabilization network | SCHWARZBECK | NSLK8127 | SHEM061-1 | 2017-12-20 | 2018-12-19 |
| Line impedance stabilization network | EMCO | 3816/2 | SHEM019-1 | 2017-12-20 | 2018-12-19 |
| Pulse limiter | Rohde & Schwarz | ESH3-Z2 | SHEM029-1 | 2017-12-20 | 2018-12-19 |
| Shielding Room | ZHONGYU | 8*4*3M | SHEM079-2 | 2017-12-20 | 2020-12-19 |
| CE test Cable | / | / | CE01 | 2017-12-26 | 2018-12-25 |

| Radiated Emissions (30MHz-1GHz) | | | | | |
|--|---------------------|-------------------|---------------------|-----------------|---------------------|
| Equipment | Manufacturer | Model No | Inventory No | Cal Date | Cal Due Date |
| EMI test receiver | Rohde & Schwarz | ESU40 | SHEM051-1 | 2017-12-20 | 2018-12-19 |
| CONTROLLER | INNCO | CO200 | SHEM047-1 | N/A | N/A |
| ANTENNA MAST | INNCO | MA400-EP | SHEM047-2 | N/A | N/A |
| TURN DEVICE | INNCO | DE 3600-RH | SHEM047-3 | N/A | N/A |
| Broadband UHF-VHF ANTENNA | SCHWARZBECK | VULB9168 | SHEM048-1 | 2017-02-28 | 2020-02-27 |
| Semi/Fully Anechoic | ST | 11*6*6M | SHEM078-2 | 2017-07-22 | 2020-07-21 |
| Low Amplifier | CLAVIIO | BDLNA-0001-412010 | SHEM164-1 | 2018-08-13 | 2019-08-12 |

| Voltage Fluctuations and Flicker | | | | | |
|---|---------------------|-----------------|---------------------|-----------------|---------------------|
| Equipment | Manufacturer | Model No | Inventory No | Cal Date | Cal Due Date |
| Harmonic&Flicker analyzer | AMETEK | PACS-1 | SHEM024-2 | 2018-08-13 | 2019-08-12 |
| AC Power Source 5KVA | AMETEK | 5001iX | SHEM025-2 | 2018-08-13 | 2019-08-12 |

| Electrostatic Discharge | | | | | |
|-----------------------------------|---------------------|-----------------|---------------------|-----------------|---------------------|
| Equipment | Manufacturer | Model No | Inventory No | Cal Date | Cal Due Date |
| Electrostatic Discharge Simulator | TESEQ | NSG 437 | SHEM041-2 | 2018-08-13 | 2019-08-12 |

| Radiated Immunity(80MHz-2.7GHz) | | | | | |
|--|---------------------|-----------------|---------------------|-----------------|---------------------|
| Equipment | Manufacturer | Model No | Inventory No | Cal Date | Cal Due Date |
| Signal generator | Rohde & Schwarz | SMJ100A | SHEM141-1 | 2018-08-13 | 2019-08-12 |
| Power Meter | Rohde & Schwarz | NRP | SHEM057-1 | 2017-12-20 | 2018-12-19 |
| Power meter sensor | Rohde & Schwarz | NRP-Z91 | SHEM057-2 | 2017-12-20 | 2018-12-19 |
| Antenna | SCHWARZBECK | STLP9128D | SHEM130-1 | N/A | N/A |
| Antenna | SCHWARZBECK | STLP9149 | SHEM131-1 | N/A | N/A |
| Amplifier | MILMEGA | 80RF1000-250 | SHEM132-1 | N/A | N/A |
| Amplifier | MILMEGA | AS0840-55-55 | SHEM133-1 | N/A | N/A |
| Power meter sensor | Rohde & Schwarz | NRP-Z22 | SHEM136-1 | 2017-12-19 | 2018-12-18 |
| ElectroMagnetic Field Probe | ETS-Lindgren | HI-6113 | SHEM134-1 | 2017-12-19 | 2018-12-18 |
| Semi/Fully Anechoic | ST | 11*6*6M | SHEM078-2 | 2017-07-22 | 2020-07-21 |

| Electrical Fast Transients/Burst at Power Port | | | | | |
|---|---------------------|-----------------|---------------------|-----------------|---------------------|
| Equipment | Manufacturer | Model No | Inventory No | Cal Date | Cal Due Date |
| Immunity Test System | EMC PARTNER | TRA3000 F-S-D-V | SHEM163-1 | 2017-12-20 | 2018-12-19 |

| Surge at Power Port | | | | | |
|----------------------------|---------------------|-----------------|---------------------|-----------------|---------------------|
| Equipment | Manufacturer | Model No | Inventory No | Cal Date | Cal Due Date |
| Immunity Test System | EMC PARTNER | TRA3000 F-S-D-V | SHEM163-1 | 2017-12-20 | 2018-12-19 |

| Conducted Immunity at Power Port (150kHz-80MHz) | | | | | |
|--|---------------------|-----------------|---------------------|-----------------|---------------------|
| Equipment | Manufacturer | Model No | Inventory No | Cal Date | Cal Due Date |
| Signal generator | Rohde & Schwarz | SMJ100A | SHEM141-1 | 2018-08-13 | 2019-08-12 |
| PAMP Conducted RF test system | HAEFFLY | PAMP250 | SHEM023-1 | 2017-12-20 | 2018-12-19 |
| 6dB Attenuator | HUAXIANG | DTS50-6dB-1G-A | SHEM123-2 | 2017-12-25 | 2018-12-24 |
| Coupling clamp | LIITHI | EM 101 | SHEM027-1 | 2017-12-20 | 2018-12-19 |
| CDN impedance and K-factor | LUTHI | L-801 M1 | SHEM023-5 | 2017-12-20 | 2018-12-19 |
| CDN impedance and K-factor | LUTHI | L-801 M2/M3 | SHEM023-6 | 2017-12-20 | 2018-12-19 |
| Shielding Room | ZHONGYU | 5*5*3M | SHEM079-6 | 2016-12-29 | 2019-12-28 |
| Coupling and Decoupling Network | Teseq | CDN M016 | SHEM168-1 | 2018-08-13 | 2019-08-12 |

| Power Frequency Magnetic Field | | | | | |
|---|---------------------|-----------------|---------------------|-----------------|---------------------|
| Equipment | Manufacturer | Model No | Inventory No | Cal Date | Cal Due Date |
| Immunity Test System | EMC PARTNER | TRA3000 F-S-D-V | SHEM163-1 | 2017-12-20 | 2018-12-19 |
| Motorised Variac | MV2616 | MV2616 | SHEM026-6 | N/A | N/A |
| Current transformer for magnetic field coil | EM test | MC2630 | SHEM026-7 | 2017-12-20 | 2018-12-19 |
| Current transformer for magnetic field coil | EM test | MC26100 | SHEM026-8 | 2017-12-20 | 2018-12-19 |
| Magnetic field coil | EM test | MS100 | SHEM026-9 | 2017-12-20 | 2018-12-19 |

| Voltage Dips and Interruptions | | | | | |
|---------------------------------------|---------------------|-----------------|---------------------|-----------------|---------------------|
| Equipment | Manufacturer | Model No | Inventory No | Cal Date | Cal Due Date |
| Immunity Test System | EMC PARTNER | TRA3000 F-S-D-V | SHEM163-1 | 2017-12-20 | 2018-12-19 |

| General used equipment | | | | | |
|-------------------------------|-----------------------------|-----------------|---------------------|-----------------|---------------------|
| Equipment | Manufacturer | Model No | Inventory No | Cal Date | Cal Due Date |
| Digital pressure meter | YONGZHI | DYM3-01 | SHEM082-1 | 2018-01-25 | 2021-01-24 |
| Temperature&humidity recorder | ShangHai weather meter work | ZJ 1-2B | SHEM042-1~6 | 2018-08-31 | 2019-08-30 |
| Digital Multimeter | FLUKE | 17B | SHEM043-3 | 2018-09-03 | 2019-09-02 |
| Autoformer regulator | Guangzhou bao de | TDGC2-5KVA | SHEM150-1 | N/A | N/A |
| Multi-purpose tong tester | FLUKE | 316 | SHEM001-1 | 2017-12-20 | 2018-12-19 |

6 Emission Test Results

6.1 Conducted Emissions at Mains Terminals (150kHz-30MHz)

| | |
|-------------------|--|
| Test Requirement: | EN 61000-6-3:2007 +A1:2011 |
| Test Method: | CISPR 16-2-1 |
| Frequency Range: | 150kHz to 30MHz |
| Limit: | |
| 0.15M-0.5MHz | 66dB(μV)-56dB(μV) quasi-peak, 56dB(μV)-46dB(μV) average |
| 0.5M-5MHz | 56dB(μV) quasi-peak, 46dB(μV) average |
| 5M-30MHz | 60dB(μV) quasi-peak, 50dB(μV) average |
| Detector: | Peak for pre-scan (9kHz resolution bandwidth) 0.15M to 30MHz |

6.1.1 E.U.T. Operation

Operating Environment:

Temperature: 22 °C Humidity: 50 % RH Atmospheric Pressure: 1002 mbar

Test mode:

- a: Keep mode CDB116A running with AC220V,
- b: Keep mode CDB116E running with AC24V,
- c: Keep mode CDB116B running with DC24V,
- d: Keep mode CDB116F running with DC12V,
- e: Keep mode CDB116C running with AC110V.

6.1.2 Test Setup Diagram

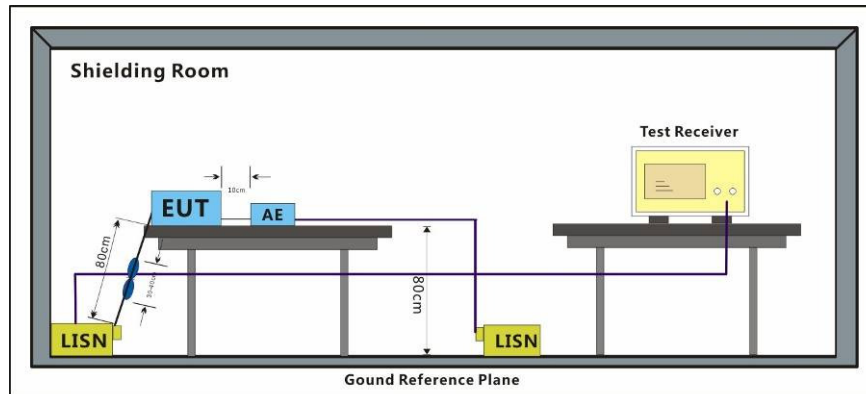

6.1.3 Measurement Data

An initial pre-scan was performed with peak detector. Quasi-Peak or Average measurement were performed at the frequencies with maximized peak emission were detected.

Mode:a; Line:Live Line

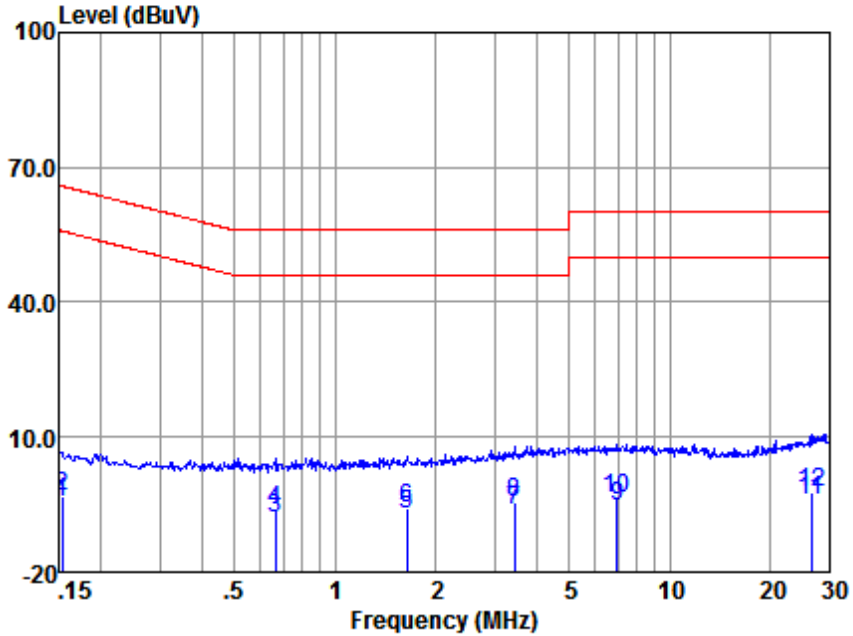

LISN : LINE
EUT/Project No : 1704TX
Test mode : a

| | Freq (MHz) | Read level (dBuV) | LISN Factor (dB) | Cable Loss (dB) | Emission Level (dBuV) | Limit (dBuV) | Over Limit (dB) | Remark |
|----|------------|-------------------|------------------|-----------------|-----------------------|--------------|-----------------|---------|
| 1 | 0.15 | -14.33 | 0.05 | 9.82 | -4.46 | 55.87 | -60.33 | Average |
| 2 | 0.15 | -13.04 | 0.05 | 9.82 | -3.17 | 65.87 | -69.04 | QP |
| 3 | 0.66 | -18.01 | 0.04 | 9.85 | -8.12 | 46.00 | -54.12 | Average |
| 4 | 0.66 | -16.32 | 0.04 | 9.85 | -6.43 | 56.00 | -62.43 | QP |
| 5 | 1.64 | -17.30 | 0.05 | 9.88 | -7.37 | 46.00 | -53.37 | Average |
| 6 | 1.64 | -15.59 | 0.05 | 9.88 | -5.66 | 56.00 | -61.66 | QP |
| 7 | 3.44 | -16.21 | 0.07 | 9.89 | -6.25 | 46.00 | -52.25 | Average |
| 8 | 3.44 | -14.41 | 0.07 | 9.89 | -4.45 | 56.00 | -60.45 | QP |
| 9 | 6.95 | -15.22 | 0.11 | 9.83 | -5.28 | 50.00 | -55.28 | Average |
| 10 | 6.95 | -13.48 | 0.11 | 9.83 | -3.54 | 60.00 | -63.54 | QP |
| 11 | 26.56 | -14.44 | 0.46 | 9.99 | -3.99 | 50.00 | -53.99 | Average |
| 12 | 26.56 | -12.76 | 0.46 | 9.99 | -2.31 | 60.00 | -62.31 | QP |

Notes: Emission Level = Read Level + LISN Factor + Cable loss

Mode:a; Line:Neutral Line

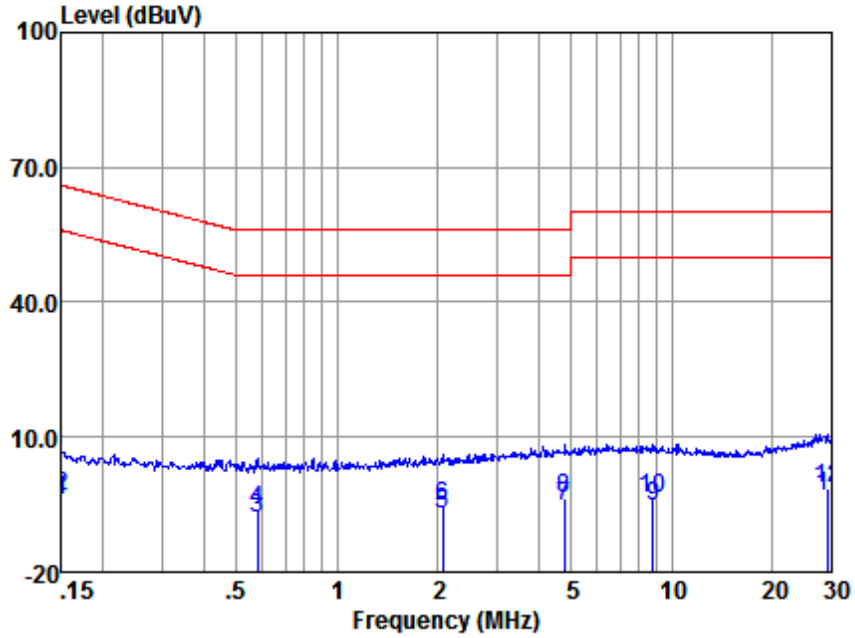

LISN : NEUTRAL
EUT/Project No : 1704TX
Test mode : a

| | Freq (MHz) | Read level (dBuV) | LISN Factor (dB) | Cable Loss (dB) | Emission Level (dBuV) | Limit (dBuV) | Over Limit (dB) | Remark |
|----|------------|-------------------|------------------|-----------------|-----------------------|--------------|-----------------|---------|
| 1 | 0.15 | -13.84 | 0.06 | 9.82 | -3.96 | 56.00 | -59.96 | Average |
| 2 | 0.15 | -12.97 | 0.06 | 9.82 | -3.09 | 66.00 | -69.09 | QP |
| 3 | 0.58 | -17.90 | 0.05 | 9.76 | -8.09 | 46.00 | -54.09 | Average |
| 4 | 0.58 | -16.17 | 0.05 | 9.76 | -6.36 | 56.00 | -62.36 | QP |
| 5 | 2.08 | -17.05 | 0.06 | 9.89 | -7.10 | 46.00 | -53.10 | Average |
| 6 | 2.08 | -15.46 | 0.06 | 9.89 | -5.51 | 56.00 | -61.51 | QP |
| 7 | 4.80 | -15.18 | 0.08 | 9.88 | -5.22 | 46.00 | -51.22 | Average |
| 8 | 4.80 | -13.72 | 0.08 | 9.88 | -3.76 | 56.00 | -59.76 | QP |
| 9 | 8.82 | -15.33 | 0.18 | 9.86 | -5.29 | 50.00 | -55.29 | Average |
| 10 | 8.82 | -13.57 | 0.18 | 9.86 | -3.53 | 60.00 | -63.53 | QP |
| 11 | 29.37 | -14.01 | 0.47 | 10.41 | -3.13 | 50.00 | -53.13 | Average |
| 12 | 29.37 | -12.39 | 0.47 | 10.41 | -1.51 | 60.00 | -61.51 | QP |

Notes: Emission Level = Read Level + LISN Factor + Cable loss

Mode:b; Line:Live Line

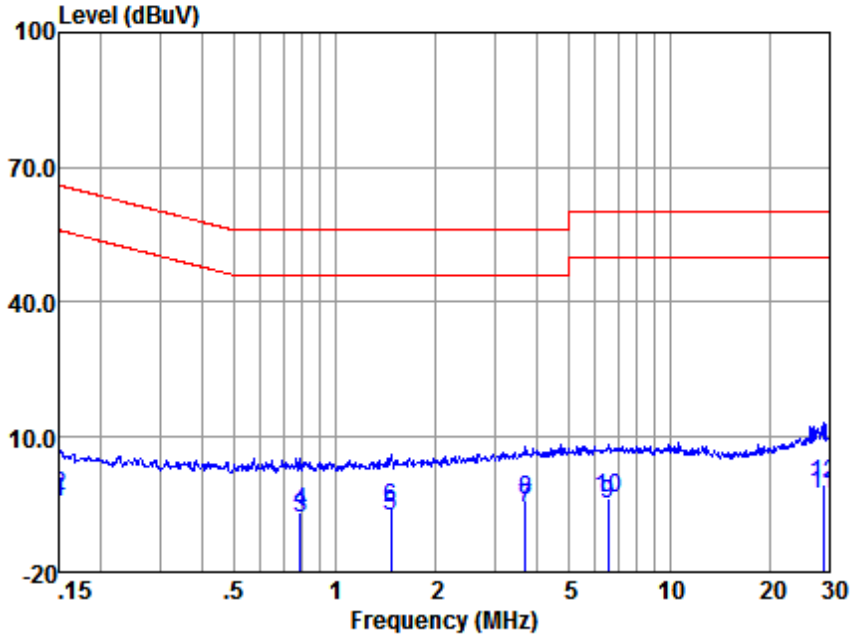

LISN : LINE
EUT/Project No : 1704TX
Test mode : b

| | Freq (MHz) | Read level (dBuV) | LISN Factor (dB) | Cable Loss (dB) | Emission Level (dBuV) | Limit (dBuV) | Over Limit (dB) | Remark |
|----|------------|-------------------|------------------|-----------------|-----------------------|--------------|-----------------|---------|
| 1 | 0.15 | -14.20 | 0.05 | 9.82 | -4.33 | 56.00 | -60.33 | Average |
| 2 | 0.15 | -12.85 | 0.05 | 9.82 | -2.98 | 66.00 | -68.98 | QP |
| 3 | 0.79 | -17.82 | 0.04 | 9.87 | -7.91 | 46.00 | -53.91 | Average |
| 4 | 0.79 | -16.41 | 0.04 | 9.87 | -6.50 | 56.00 | -62.50 | QP |
| 5 | 1.47 | -17.45 | 0.05 | 9.86 | -7.54 | 46.00 | -53.54 | Average |
| 6 | 1.47 | -15.81 | 0.05 | 9.86 | -5.90 | 56.00 | -61.90 | QP |
| 7 | 3.72 | -15.69 | 0.07 | 9.94 | -5.68 | 46.00 | -51.68 | Average |
| 8 | 3.72 | -14.22 | 0.07 | 9.94 | -4.21 | 56.00 | -60.21 | QP |
| 9 | 6.56 | -14.94 | 0.10 | 9.82 | -5.02 | 50.00 | -55.02 | Average |
| 10 | 6.56 | -13.41 | 0.10 | 9.82 | -3.49 | 60.00 | -63.49 | QP |
| 11 | 28.75 | -13.56 | 0.47 | 10.33 | -2.76 | 50.00 | -52.76 | Average |
| 12 | 28.75 | -11.39 | 0.47 | 10.33 | -0.59 | 60.00 | -60.59 | QP |

Notes: Emission Level = Read Level + LISN Factor + Cable loss

Mode:b; Line:Neutral Line

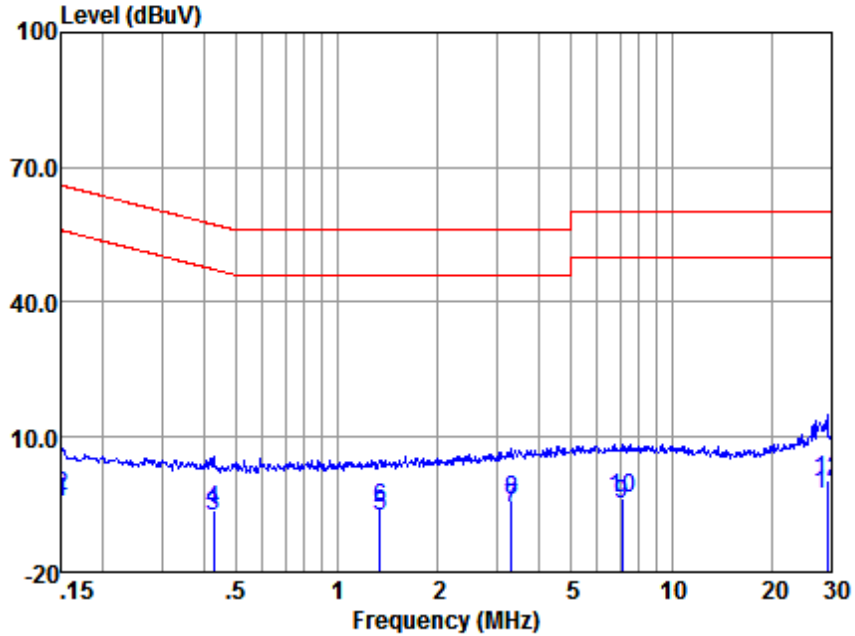

LISN : NEUTRAL
EUT/Project No : 1704TX
Test mode : b

| | Freq (MHz) | Read level (dBuV) | LISN Factor (dB) | Cable Loss (dB) | Emission Level (dBuV) | Limit (dBuV) | Over Limit (dB) | Remark |
|----|------------|-------------------|------------------|-----------------|-----------------------|--------------|-----------------|---------|
| 1 | 0.15 | -14.21 | 0.06 | 9.82 | -4.33 | 56.00 | -60.33 | Average |
| 2 | 0.15 | -12.92 | 0.06 | 9.82 | -3.04 | 66.00 | -69.04 | QP |
| 3 | 0.43 | -17.45 | 0.05 | 9.84 | -7.56 | 47.29 | -54.85 | Average |
| 4 | 0.43 | -15.99 | 0.05 | 9.84 | -6.10 | 57.29 | -63.39 | QP |
| 5 | 1.34 | -17.67 | 0.06 | 9.85 | -7.76 | 46.00 | -53.76 | Average |
| 6 | 1.34 | -15.85 | 0.06 | 9.85 | -5.94 | 56.00 | -61.94 | QP |
| 7 | 3.33 | -15.99 | 0.07 | 9.90 | -6.02 | 46.00 | -52.02 | Average |
| 8 | 3.33 | -14.02 | 0.07 | 9.90 | -4.05 | 56.00 | -60.05 | QP |
| 9 | 7.14 | -15.00 | 0.12 | 9.84 | -5.04 | 50.00 | -55.04 | Average |
| 10 | 7.14 | -13.58 | 0.12 | 9.84 | -3.62 | 60.00 | -63.62 | QP |
| 11 | 29.22 | -13.55 | 0.47 | 10.41 | -2.67 | 50.00 | -52.67 | Average |
| 12 | 29.22 | -10.62 | 0.47 | 10.41 | 0.26 | 60.00 | -59.74 | QP |

Notes: Emission Level = Read Level + LISN Factor + Cable loss

Mode:c; Line:Live Line

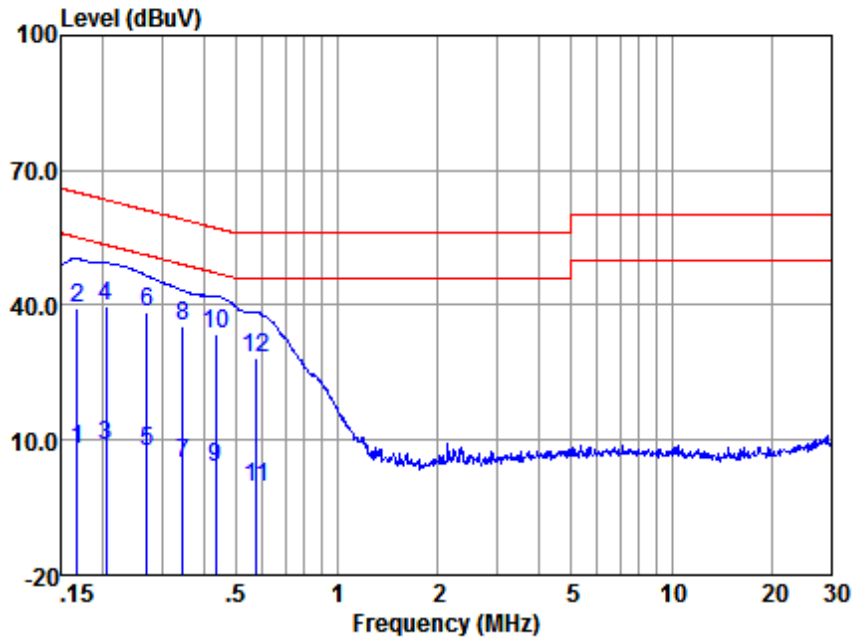

LISN : LINE
EUT/Project No : 1704TX
Test mode : c

| Freq (MHz) | Read level (dBuV) | LISN Factor (dB) | Cable Loss (dB) | Emission Level (dBuV) | Limit (dBuV) | Over Limit (dB) | Remark |
|------------|-------------------|------------------|-----------------|-----------------------|--------------|-----------------|---------|
| 1 | 0.17 | -2.01 | 0.05 | 7.87 | 55.08 | -47.21 | Average |
| 2 | 0.17 | 29.46 | 0.05 | 39.34 | 65.08 | -25.74 | QP |
| 3 | 0.20 | -1.17 | 0.05 | 8.71 | 53.45 | -44.74 | Average |
| 4 | 0.20 | 29.99 | 0.05 | 39.87 | 63.45 | -23.58 | QP |
| 5 | 0.27 | -2.65 | 0.05 | 7.25 | 51.12 | -43.87 | Average |
| 6 | 0.27 | 28.70 | 0.05 | 38.60 | 61.12 | -22.52 | QP |
| 7 | 0.35 | -5.29 | 0.05 | 4.60 | 49.05 | -44.45 | Average |
| 8 | 0.35 | 25.38 | 0.05 | 35.27 | 59.05 | -23.78 | QP |
| 9 | 0.43 | -6.17 | 0.05 | 3.72 | 47.20 | -43.48 | Average |
| 10 | 0.43 | 23.83 | 0.05 | 33.72 | 57.20 | -23.48 | QP |
| 11 | 0.57 | -10.49 | 0.05 | -0.68 | 46.00 | -46.68 | Average |
| 12 | 0.57 | 18.27 | 0.05 | 28.08 | 56.00 | -27.92 | QP |

Notes: Emission Level = Read Level + LISN Factor + Cable loss

Mode:c; Line:Neutral Line

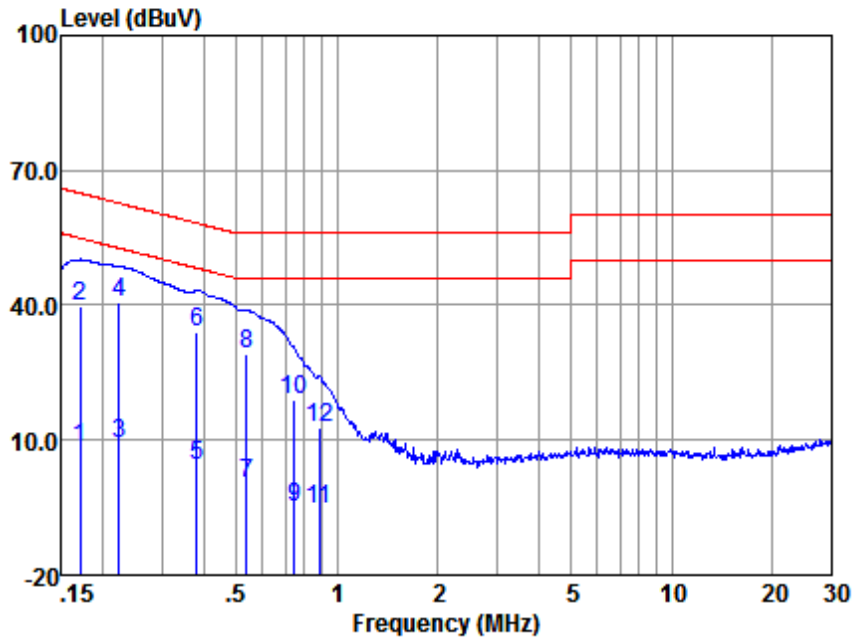

LISN : NEUTRAL
EUT/Project No : 1704TX
Test mode : c

| Freq (MHz) | Read level (dBuV) | LISN Factor (dB) | Cable Loss (dB) | Emission Level (dBuV) | Limit (dBuV) | Over Limit (dB) | Remark |
|------------|-------------------|------------------|-----------------|-----------------------|--------------|-----------------|---------|
| 1 | 0.17 | -1.61 | 0.06 | 9.83 | 54.94 | -46.66 | Average |
| 2 | 0.17 | 29.97 | 0.06 | 9.83 | 64.94 | -25.08 | QP |
| 3 | 0.22 | -0.49 | 0.06 | 9.84 | 52.70 | -43.29 | Average |
| 4 | 0.22 | 30.97 | 0.06 | 9.84 | 62.70 | -21.83 | QP |
| 5 | 0.38 | -5.58 | 0.05 | 9.85 | 48.25 | -43.93 | Average |
| 6 | 0.38 | 24.31 | 0.05 | 9.85 | 58.25 | -24.04 | QP |
| 7 | 0.54 | -9.25 | 0.05 | 9.76 | 46.00 | -45.44 | Average |
| 8 | 0.54 | 19.40 | 0.05 | 9.76 | 56.00 | -26.79 | QP |
| 9 | 0.75 | -14.78 | 0.05 | 9.86 | 46.00 | -50.87 | Average |
| 10 | 0.75 | 9.07 | 0.05 | 9.86 | 56.00 | -37.02 | QP |
| 11 | 0.88 | -15.48 | 0.05 | 9.88 | 46.00 | -51.55 | Average |
| 12 | 0.88 | 2.91 | 0.05 | 9.88 | 56.00 | -43.16 | QP |

Notes: Emission Level = Read Level + LISN Factor + Cable loss

Mode:d; Line:Live Line

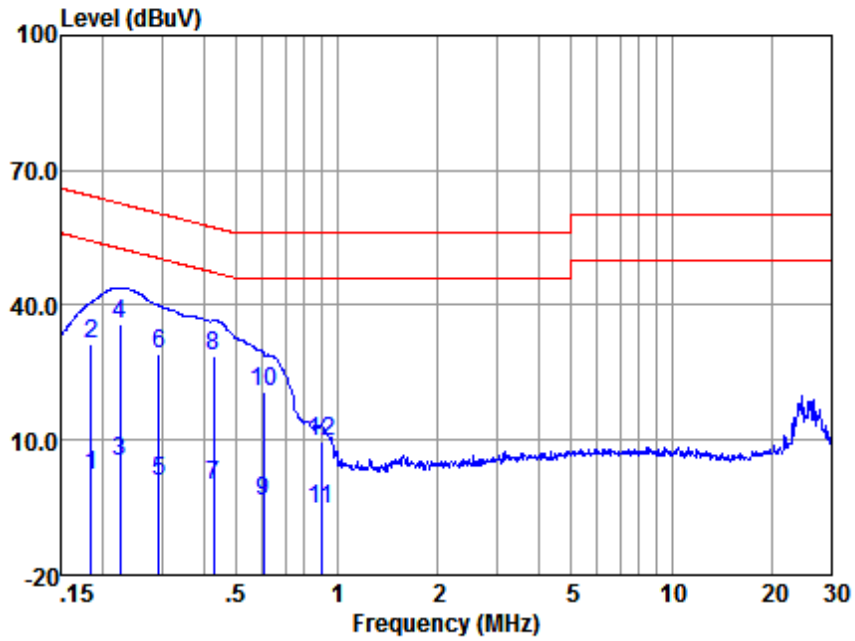

LISN : LINE
EUT/Project No : 1704TX
Test mode : d

| Freq (MHz) | Read level (dBuV) | LISN Factor (dB) | Cable Loss (dB) | Emission Level (dBuV) | Limit (dBuV) | Over Limit (dB) | Remark | |
|------------|-------------------|------------------|-----------------|-----------------------|--------------|-----------------|--------|---------|
| 1 | 0.18 | -7.66 | 0.05 | 9.83 | 2.22 | 54.33 | -52.11 | Average |
| 2 | 0.18 | 21.52 | 0.05 | 9.83 | 31.40 | 64.33 | -32.93 | QP |
| 3 | 0.22 | -4.84 | 0.05 | 9.84 | 5.05 | 52.66 | -47.61 | Average |
| 4 | 0.22 | 25.69 | 0.05 | 9.84 | 35.58 | 62.66 | -27.08 | QP |
| 5 | 0.29 | -9.12 | 0.05 | 9.85 | 0.78 | 50.41 | -49.63 | Average |
| 6 | 0.29 | 19.36 | 0.05 | 9.85 | 29.26 | 60.41 | -31.15 | QP |
| 7 | 0.43 | -9.85 | 0.05 | 9.84 | 0.04 | 47.29 | -47.25 | Average |
| 8 | 0.43 | 18.70 | 0.05 | 9.84 | 28.59 | 57.29 | -28.70 | QP |
| 9 | 0.60 | -13.53 | 0.04 | 9.78 | -3.71 | 46.00 | -49.71 | Average |
| 10 | 0.60 | 10.74 | 0.04 | 9.78 | 20.56 | 56.00 | -35.44 | QP |
| 11 | 0.90 | -15.29 | 0.05 | 9.88 | -5.36 | 46.00 | -51.36 | Average |
| 12 | 0.90 | -0.32 | 0.05 | 9.88 | 9.61 | 56.00 | -46.39 | QP |

Notes: Emission Level = Read Level + LISN Factor + Cable loss

Mode:d; Line:Neutral Line

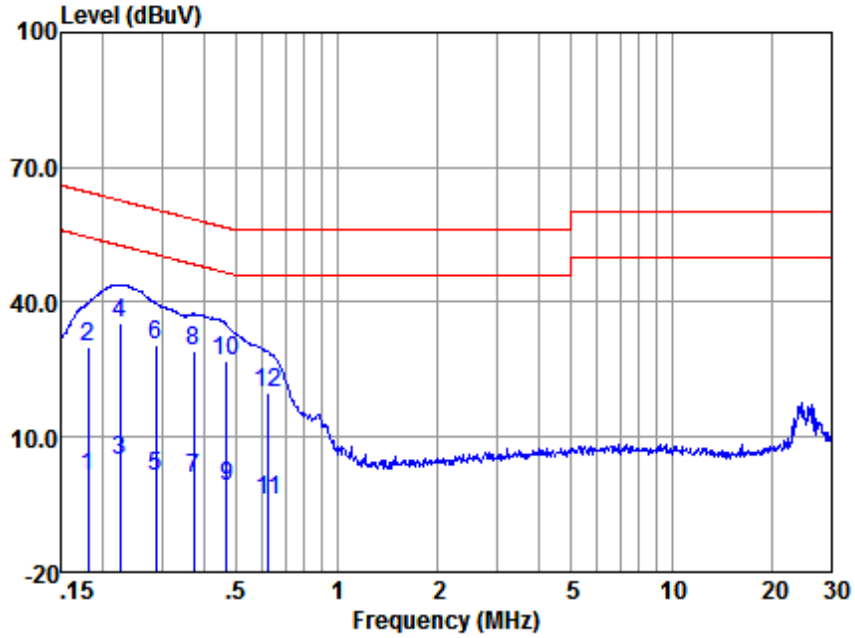

LISN : NEUTRAL
EUT/Project No : 1704TX
Test mode : d

| | Freq (MHz) | Read level (dBuV) | LISN Factor (dB) | Cable Loss (dB) | Emission Level (dBuV) | Limit (dBuV) | Over Limit (dB) | Remark |
|----|------------|-------------------|------------------|-----------------|-----------------------|--------------|-----------------|---------|
| 1 | 0.18 | -8.48 | 0.06 | 9.83 | 1.41 | 54.50 | -53.09 | Average |
| 2 | 0.18 | 20.24 | 0.06 | 9.83 | 30.13 | 64.50 | -34.37 | QP |
| 3 | 0.22 | -5.04 | 0.06 | 9.84 | 4.86 | 52.66 | -47.80 | Average |
| 4 | 0.22 | 25.32 | 0.06 | 9.84 | 35.22 | 62.66 | -27.44 | QP |
| 5 | 0.29 | -8.60 | 0.06 | 9.85 | 1.31 | 50.59 | -49.28 | Average |
| 6 | 0.29 | 20.47 | 0.06 | 9.85 | 30.38 | 60.59 | -30.21 | QP |
| 7 | 0.37 | -9.13 | 0.05 | 9.84 | 0.76 | 48.43 | -47.67 | Average |
| 8 | 0.37 | 19.37 | 0.05 | 9.84 | 29.26 | 58.43 | -29.17 | QP |
| 9 | 0.47 | -10.61 | 0.05 | 9.82 | -0.74 | 46.58 | -47.32 | Average |
| 10 | 0.47 | 17.18 | 0.05 | 9.82 | 27.05 | 56.58 | -29.53 | QP |
| 11 | 0.62 | -13.96 | 0.05 | 9.80 | -4.11 | 46.00 | -50.11 | Average |
| 12 | 0.62 | 9.90 | 0.05 | 9.80 | 19.75 | 56.00 | -36.25 | QP |

Notes: Emission Level = Read Level + LISN Factor + Cable loss

Mode:e; Line:Live Line

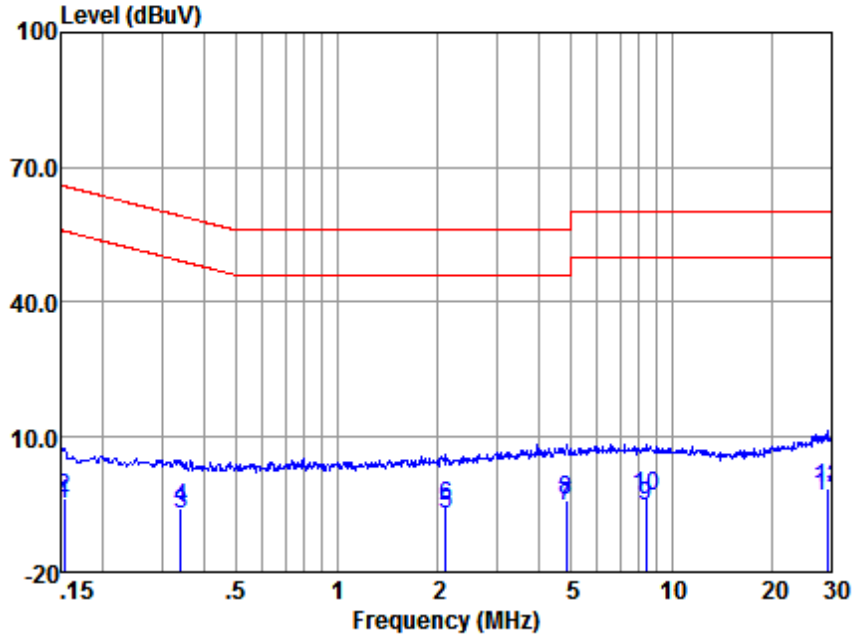

LISN : LINE
EUT/Project No : 1704TX
Test mode : e

| | Freq (MHz) | Read level (dBuV) | LISN Factor (dB) | Cable Loss (dB) | Emission Level (dBuV) | Limit (dBuV) | Over Limit (dB) | Remark |
|----|------------|-------------------|------------------|-----------------|-----------------------|--------------|-----------------|---------|
| 1 | 0.15 | -14.70 | 0.05 | 9.82 | -4.83 | 55.87 | -60.70 | Average |
| 2 | 0.15 | -13.55 | 0.05 | 9.82 | -3.68 | 65.87 | -69.55 | QP |
| 3 | 0.34 | -17.23 | 0.05 | 9.84 | -7.34 | 49.18 | -56.52 | Average |
| 4 | 0.34 | -15.51 | 0.05 | 9.84 | -5.62 | 59.18 | -64.80 | QP |
| 5 | 2.11 | -16.90 | 0.05 | 9.89 | -6.96 | 46.00 | -52.96 | Average |
| 6 | 2.11 | -15.51 | 0.05 | 9.89 | -5.57 | 56.00 | -61.57 | QP |
| 7 | 4.85 | -15.18 | 0.08 | 9.90 | -5.20 | 46.00 | -51.20 | Average |
| 8 | 4.85 | -13.90 | 0.08 | 9.90 | -3.92 | 56.00 | -59.92 | QP |
| 9 | 8.37 | -15.29 | 0.16 | 9.89 | -5.24 | 50.00 | -55.24 | Average |
| 10 | 8.37 | -13.26 | 0.16 | 9.89 | -3.21 | 60.00 | -63.21 | QP |
| 11 | 29.22 | -14.16 | 0.47 | 10.41 | -3.28 | 50.00 | -53.28 | Average |
| 12 | 29.22 | -12.15 | 0.47 | 10.41 | -1.27 | 60.00 | -61.27 | QP |

Notes: Emission Level = Read Level + LISN Factor + Cable loss

Mode:e; Line:Neutral Line

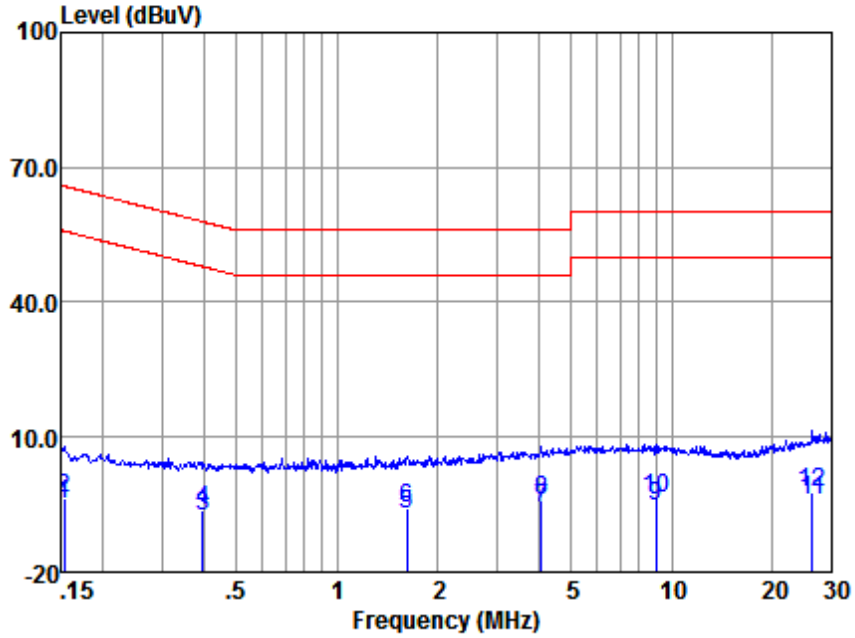

LISN : NEUTRAL
EUT/Project No : 1704TX
Test mode : e

| | Freq (MHz) | Read level (dBuV) | LISN Factor (dB) | Cable Loss (dB) | Emission Level (dBuV) | Limit (dBuV) | Over Limit (dB) | Remark |
|----|------------|-------------------|------------------|-----------------|-----------------------|--------------|-----------------|---------|
| 1 | 0.15 | -14.71 | 0.06 | 9.82 | -4.83 | 55.87 | -60.70 | Average |
| 2 | 0.15 | -13.38 | 0.06 | 9.82 | -3.50 | 65.87 | -69.37 | QP |
| 3 | 0.40 | -17.60 | 0.05 | 9.85 | -7.70 | 47.95 | -55.65 | Average |
| 4 | 0.40 | -16.20 | 0.05 | 9.85 | -6.30 | 57.95 | -64.25 | QP |
| 5 | 1.62 | -17.26 | 0.06 | 9.89 | -7.31 | 46.00 | -53.31 | Average |
| 6 | 1.62 | -15.76 | 0.06 | 9.89 | -5.81 | 56.00 | -61.81 | QP |
| 7 | 4.09 | -15.58 | 0.08 | 9.88 | -5.62 | 46.00 | -51.62 | Average |
| 8 | 4.09 | -13.93 | 0.08 | 9.88 | -3.97 | 56.00 | -59.97 | QP |
| 9 | 9.01 | -15.34 | 0.18 | 9.85 | -5.31 | 50.00 | -55.31 | Average |
| 10 | 9.01 | -13.76 | 0.18 | 9.85 | -3.73 | 60.00 | -63.73 | QP |
| 11 | 26.42 | -14.46 | 0.45 | 9.98 | -4.03 | 50.00 | -54.03 | Average |
| 12 | 26.42 | -12.70 | 0.45 | 9.98 | -2.27 | 60.00 | -62.27 | QP |

Notes: Emission Level = Read Level + LISN Factor + Cable loss

6.2 Radiated Emissions (30MHz-1GHz)

Test Requirement: EN 61000-6-3:2007 +A1:2011
 Test Method: CISPR 16-2-3
 Frequency Range: 30MHz to 1GHz
 Measurement Distance: 3m
 Limit:
 30MHz-230MHz 40 dB(μ V/m) quasi-peak
 230MHz-1GHz 47 dB(μ V/m) quasi-peak
 Detector: Peak for pre-scan (120kHz resolution bandwidth) 30M to 1000MHz

6.2.1 E.U.T. Operation

Operating Environment:

Temperature: 22 °C Humidity: 50 % RH Atmospheric Pressure: 1020 mbar

Test mode:
 a: Keep mode CDB116A running with AC220V,
 b: Keep mode CDB116E running with AC24V,
 c: Keep mode CDB116B running with DC24V,
 d: Keep mode CDB116F running with DC12V,
 e: Keep mode CDB116C running with AC110V.

6.2.2 Test Setup Diagram

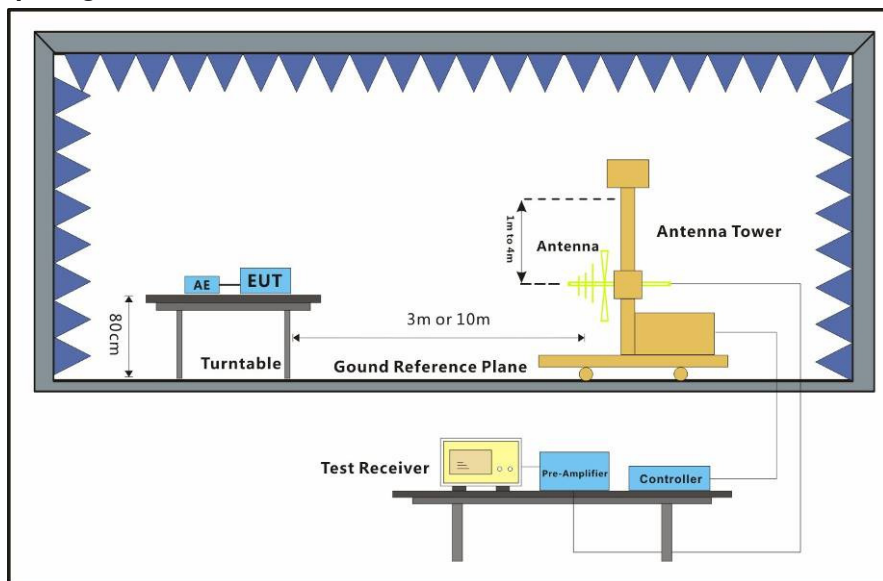

6.2.3 Measurement Data

An initial pre-scan was performed in the chamber using the spectrum analyser in peak detection mode. Quasi-peak measurements were conducted based on the peak sweep graph. The EUT was measured by BiConiLog antenna with 2 orthogonal polarities.

Mode:a; Polarization:Horizontal

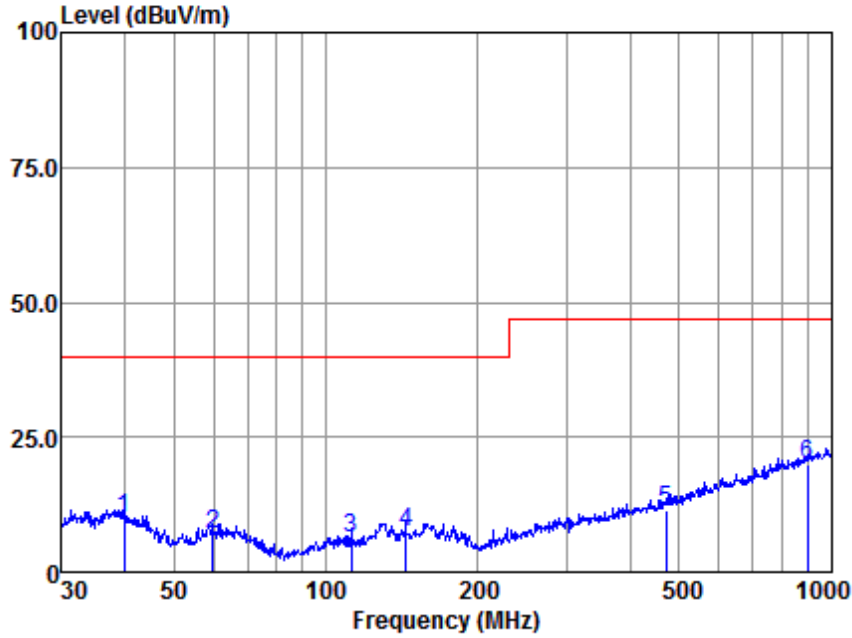

Antenna Polarity :HORIZONTAL
EUT/Project :1704TX
Test mode :a

| | Freq | Read Level | Antenna Factor | Cable Loss | Preamp Factor | Emission Level | Limit Line | Over Limit | Remark |
|---|--------|------------|----------------|------------|---------------|----------------|------------|------------|--------|
| | MHz | dBuv | dB/m | dB | dB | dBuv/m | dBuv/m | dB | |
| 1 | 39.85 | 35.68 | 16.29 | 0.78 | 42.62 | 10.13 | 40.00 | -29.87 | QP |
| 2 | 59.65 | 36.24 | 12.52 | 0.89 | 42.65 | 7.00 | 40.00 | -33.00 | QP |
| 3 | 112.13 | 38.48 | 9.68 | 0.73 | 42.70 | 6.19 | 40.00 | -33.81 | QP |
| 4 | 143.83 | 37.71 | 11.54 | 0.57 | 42.62 | 7.20 | 40.00 | -32.80 | QP |
| 5 | 470.52 | 36.01 | 16.63 | 0.97 | 42.13 | 11.48 | 47.00 | -35.52 | QP |
| 6 | 897.00 | 36.62 | 22.68 | 2.38 | 41.90 | 19.78 | 47.00 | -27.22 | QP |

Note:Emission Level=Read Level+Antenna Factor+Cable loss-Preamp Factor

Mode:a; Polarization:Vertical

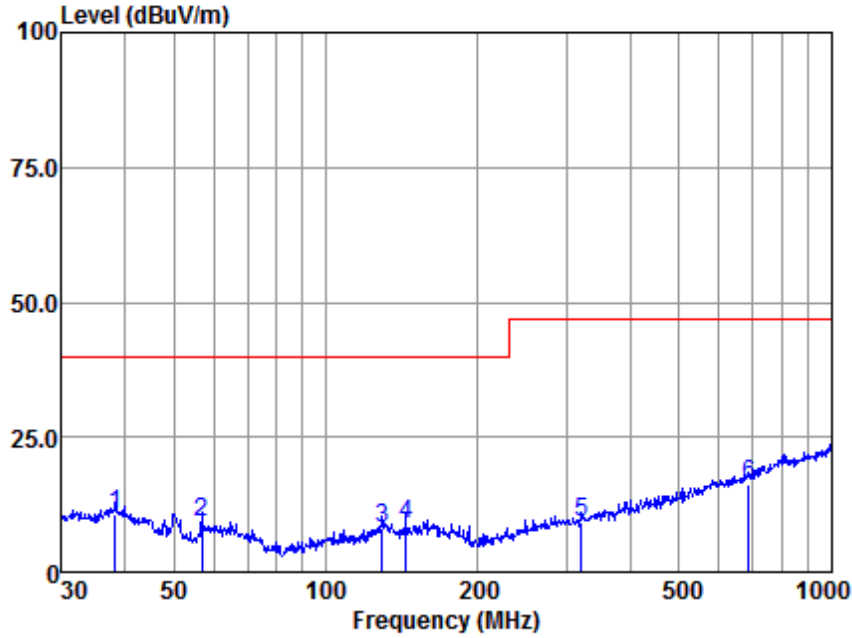

Antenna Polarity :VERTICAL
EUT/Project :1704TX
Test mode :a

| | Freq | Read Level | Antenna Factor | Cable Loss | Preamp Factor | Emission Level | Limit Line | Over Limit | Remark |
|---|--------|------------|----------------|------------|---------------|----------------|------------|------------|--------|
| | MHz | dBuv | dB/m | dB | dB | dBuv/m | dBuv/m | dB | |
| 1 | 38.35 | 36.48 | 16.15 | 0.75 | 42.62 | 10.76 | 40.00 | -29.24 | QP |
| 2 | 56.79 | 38.90 | 11.98 | 0.90 | 42.65 | 9.13 | 40.00 | -30.87 | QP |
| 3 | 129.47 | 37.63 | 12.68 | 0.64 | 42.66 | 8.29 | 40.00 | -31.71 | QP |
| 4 | 143.83 | 39.51 | 11.54 | 0.57 | 42.62 | 9.00 | 40.00 | -31.00 | QP |
| 5 | 321.06 | 37.06 | 13.64 | 0.71 | 42.33 | 9.08 | 47.00 | -37.92 | QP |
| 6 | 687.15 | 36.72 | 20.11 | 1.88 | 42.37 | 16.34 | 47.00 | -30.66 | QP |

Note:Emission Level=Read Level+Antenna Factor+Cable loss-Preamp Factor

Mode:b; Polarization:Horizontal

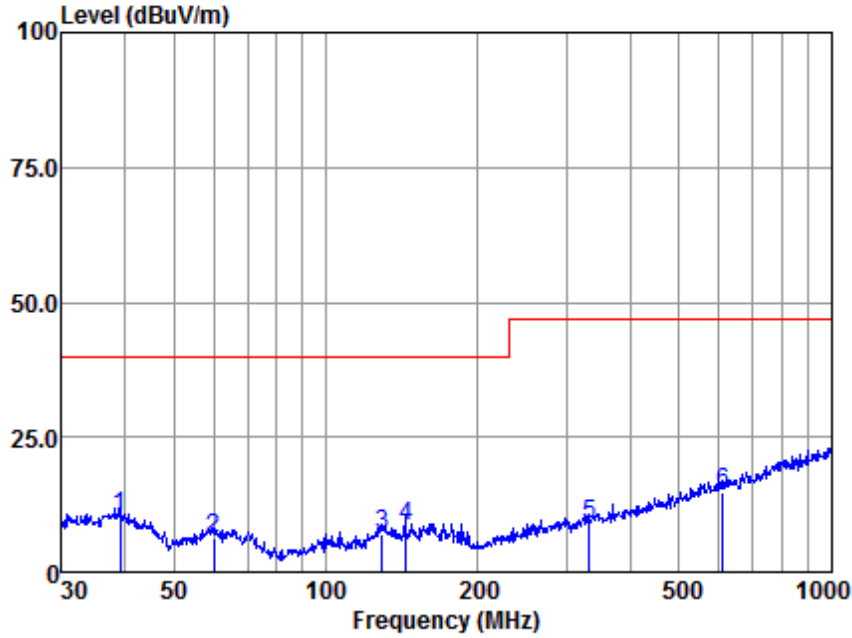

Antenna Polarity :HORIZONTAL
EUT/Project :1704TX
Test mode :b

| | Freq | Read Level | Antenna Factor | Cable Loss | Preamp Factor | Emission Level | Limit Line | Over Limit | Remark |
|---|--------|------------|----------------|------------|---------------|----------------|------------|------------|--------|
| | MHz | dBuv | dB/m | dB | dB | dBuv/m | dBuv/m | dB | |
| 1 | 39.16 | 35.89 | 16.23 | 0.77 | 42.62 | 10.27 | 40.00 | -29.73 | QP |
| 2 | 60.07 | 35.31 | 12.60 | 0.89 | 42.65 | 6.15 | 40.00 | -33.85 | QP |
| 3 | 129.47 | 36.28 | 12.68 | 0.64 | 42.66 | 6.94 | 40.00 | -33.06 | QP |
| 4 | 143.83 | 38.81 | 11.54 | 0.57 | 42.62 | 8.30 | 40.00 | -31.70 | QP |
| 5 | 332.52 | 36.51 | 13.87 | 0.73 | 42.29 | 8.82 | 47.00 | -38.18 | QP |
| 6 | 609.92 | 35.99 | 19.49 | 1.57 | 42.19 | 14.86 | 47.00 | -32.14 | QP |

Note:Emission Level=Read Level+Antenna Factor+Cable loss-Preamp Factor

Mode:b; Polarization:Vertical

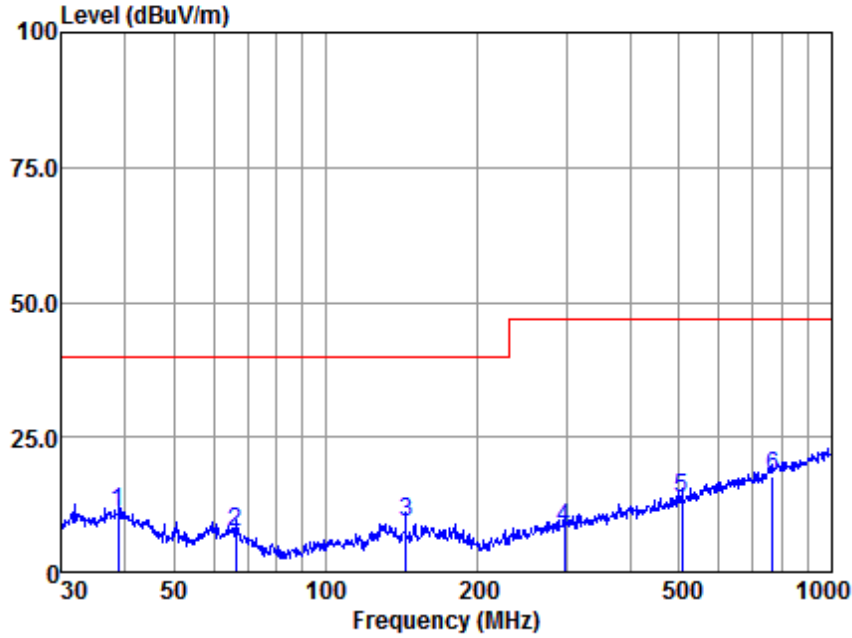

Antenna Polarity :VERTICAL
EUT/Project :1704TX
Test mode :b

| | Freq | Read Level | Antenna Factor | Cable Loss | Preamp Factor | Emission Level | Limit Line | Over Limit | Remark |
|---|--------|------------|----------------|------------|---------------|----------------|------------|------------|--------|
| | MHz | dBuv | dB/m | dB | dB | dBuv/m | dBuv/m | dB | |
| 1 | 38.89 | 36.84 | 16.20 | 0.77 | 42.62 | 11.19 | 40.00 | -28.81 | QP |
| 2 | 66.27 | 37.49 | 11.84 | 0.87 | 42.66 | 7.54 | 40.00 | -32.46 | QP |
| 3 | 143.83 | 39.63 | 11.54 | 0.57 | 42.62 | 9.12 | 40.00 | -30.88 | QP |
| 4 | 296.18 | 36.69 | 13.07 | 0.65 | 42.40 | 8.01 | 47.00 | -38.99 | QP |
| 5 | 506.48 | 37.37 | 17.37 | 1.07 | 42.15 | 13.66 | 47.00 | -33.34 | QP |
| 6 | 766.06 | 36.87 | 21.36 | 2.09 | 42.57 | 17.75 | 47.00 | -29.25 | QP |

Note:Emission Level=Read Level+Antenna Factor+Cable loss-Preamp Factor

Mode:c; Polarization:Horizontal

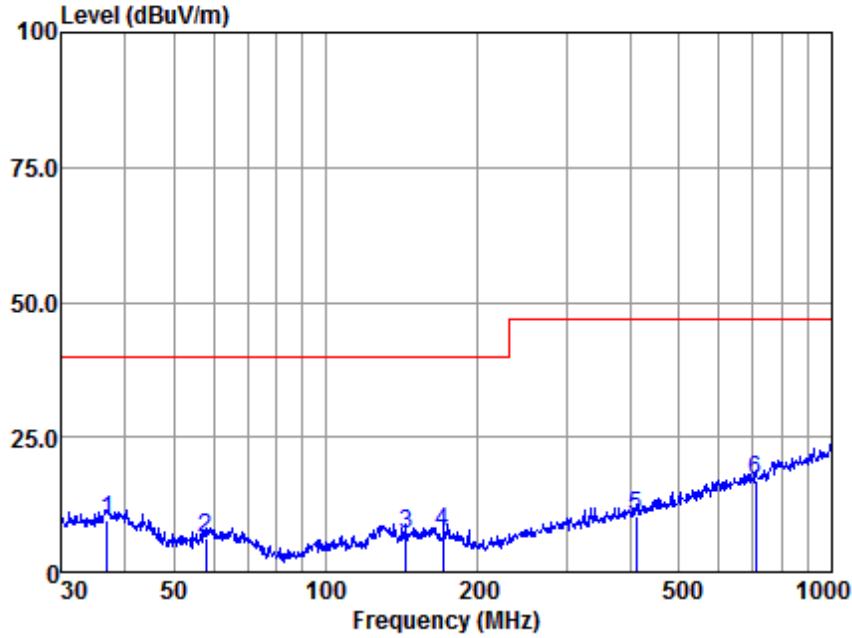

Antenna Polarity :HORIZONTAL
EUT/Project :1704TX
Test mode :c

| | Freq | Read Level | Antenna Factor | Cable Loss | Preamp Factor | Emission Level | Limit Line | Over Limit | Remark |
|---|--------|------------|----------------|------------|---------------|----------------|------------|------------|--------|
| | MHz | dBuv | dB/m | dB | dB | dBuv/m | dBuv/m | dB | |
| 1 | 36.90 | 35.40 | 16.02 | 0.73 | 42.62 | 9.53 | 40.00 | -30.47 | QP |
| 2 | 58.00 | 35.79 | 12.22 | 0.89 | 42.65 | 6.25 | 40.00 | -33.75 | QP |
| 3 | 143.83 | 37.39 | 11.54 | 0.57 | 42.62 | 6.88 | 40.00 | -33.12 | QP |
| 4 | 170.79 | 37.86 | 11.62 | 0.47 | 42.57 | 7.38 | 40.00 | -32.62 | QP |
| 5 | 410.38 | 36.35 | 15.33 | 0.87 | 42.10 | 10.45 | 47.00 | -36.55 | QP |
| 6 | 709.18 | 37.06 | 20.38 | 1.93 | 42.44 | 16.93 | 47.00 | -30.07 | QP |

Note:Emission Level=Read Level+Antenna Factor+Cable loss-Preamp Factor

Mode:c; Polarization:Vertical

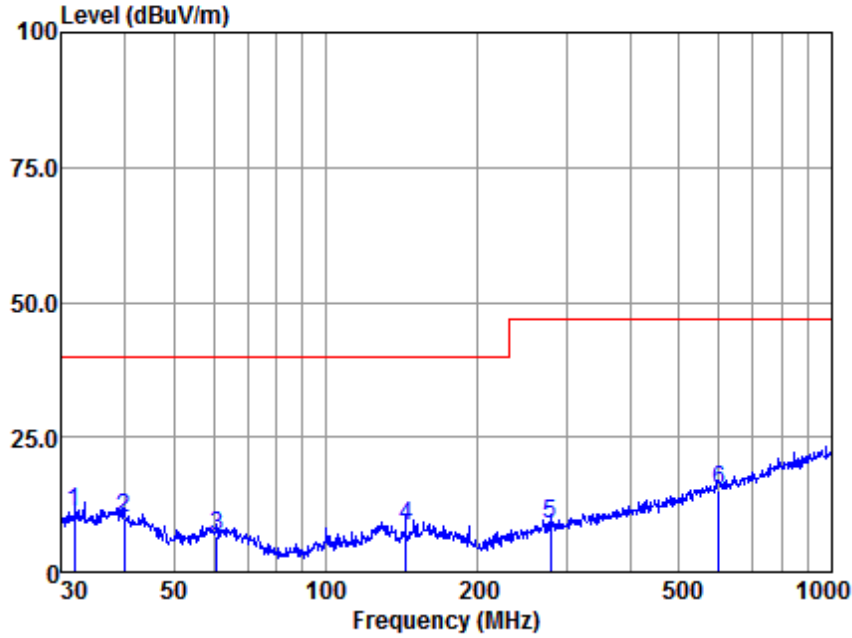

Antenna Polarity :VERTICAL
EUT/Project :1704TX
Test mode :c

| | Freq | Read Level | Antenna Factor | Cable Loss | Preamp Factor | Emission Level | Limit Line | Over Limit | Remark |
|---|--------|------------|----------------|------------|---------------|----------------|------------|------------|--------|
| | MHz | dBuv | dB/m | dB | dB | dBuv/m | dBuv/m | dB | |
| 1 | 31.84 | 37.45 | 15.51 | 0.64 | 42.61 | 10.99 | 40.00 | -29.01 | QP |
| 2 | 39.85 | 35.49 | 16.29 | 0.78 | 42.62 | 9.94 | 40.00 | -30.06 | QP |
| 3 | 60.92 | 36.00 | 12.49 | 0.88 | 42.65 | 6.72 | 40.00 | -33.28 | QP |
| 4 | 143.83 | 38.88 | 11.54 | 0.57 | 42.62 | 8.37 | 40.00 | -31.63 | QP |
| 5 | 278.07 | 38.13 | 12.48 | 0.61 | 42.42 | 8.80 | 47.00 | -38.20 | QP |
| 6 | 599.32 | 36.44 | 19.40 | 1.48 | 42.19 | 15.13 | 47.00 | -31.87 | QP |

Note:Emission Level=Read Level+Antenna Factor+Cable loss-Preamp Factor

Mode:d; Polarization:Horizontal

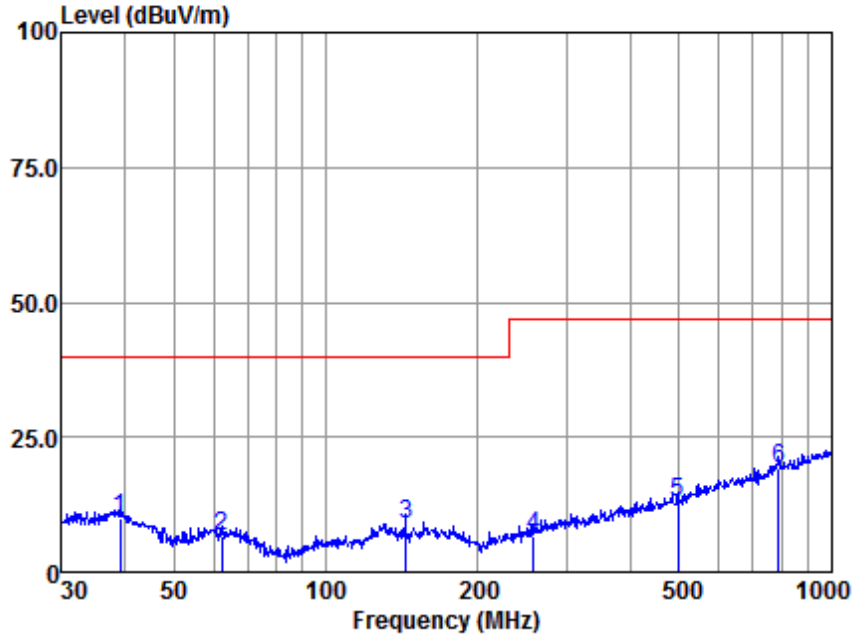

Antenna Polarity :HORIZONTAL
EUT/Project :1704TX
Test mode :d

| | Freq | Read Level | Antenna Factor | Cable Loss | Preamp Factor | Emission Level | Limit Line | Over Limit | Remark |
|---|--------|------------|----------------|------------|---------------|----------------|------------|------------|--------|
| | MHz | dBuv | dB/m | dB | dB | dBuv/m | dBuv/m | dB | |
| 1 | 39.16 | 35.65 | 16.23 | 0.77 | 42.62 | 10.03 | 40.00 | -29.97 | QP |
| 2 | 62.21 | 36.02 | 12.33 | 0.88 | 42.66 | 6.57 | 40.00 | -33.43 | QP |
| 3 | 143.83 | 39.25 | 11.54 | 0.57 | 42.62 | 8.74 | 40.00 | -31.26 | QP |
| 4 | 257.42 | 36.80 | 11.76 | 0.56 | 42.45 | 6.67 | 47.00 | -40.33 | QP |
| 5 | 497.68 | 36.85 | 17.17 | 1.01 | 42.14 | 12.89 | 47.00 | -34.11 | QP |
| 6 | 787.85 | 37.88 | 21.72 | 2.13 | 42.47 | 19.26 | 47.00 | -27.74 | QP |

Note:Emission Level=Read Level+Antenna Factor+Cable loss-Preamp Factor

Mode:d; Polarization:Vertical

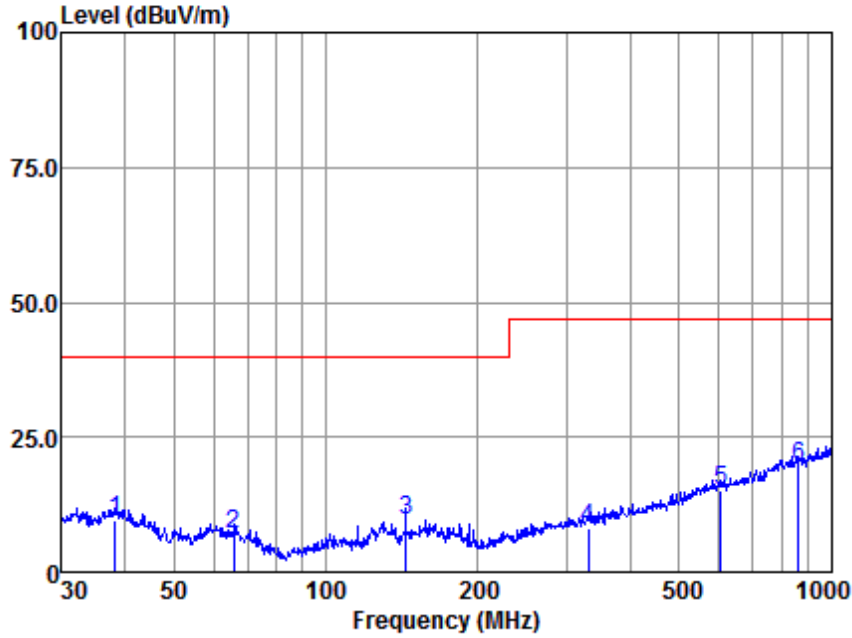

Antenna Polarity :VERTICAL
EUT/Project :1704TX
Test mode :d

| | Freq | Read Level | Antenna Factor | Cable Loss | Preamp Factor | Emission Level | Limit Line | Over Limit | Remark |
|---|--------|------------|----------------|------------|---------------|----------------|------------|------------|--------|
| | MHz | dBuv | dB/m | dB | dB | dBuv/m | dBuv/m | dB | |
| 1 | 38.35 | 35.47 | 16.15 | 0.75 | 42.62 | 9.75 | 40.00 | -30.25 | QP |
| 2 | 65.80 | 36.79 | 11.89 | 0.87 | 42.66 | 6.89 | 40.00 | -33.11 | QP |
| 3 | 143.83 | 40.17 | 11.54 | 0.57 | 42.62 | 9.66 | 40.00 | -30.34 | QP |
| 4 | 330.19 | 35.88 | 13.83 | 0.72 | 42.30 | 8.13 | 47.00 | -38.87 | QP |
| 5 | 605.66 | 36.35 | 19.45 | 1.54 | 42.19 | 15.15 | 47.00 | -31.85 | QP |
| 6 | 863.06 | 36.84 | 22.42 | 2.33 | 42.15 | 19.44 | 47.00 | -27.56 | QP |

Note:Emission Level=Read Level+Antenna Factor+Cable loss-Preamp Factor

Mode:e; Polarization:Horizontal

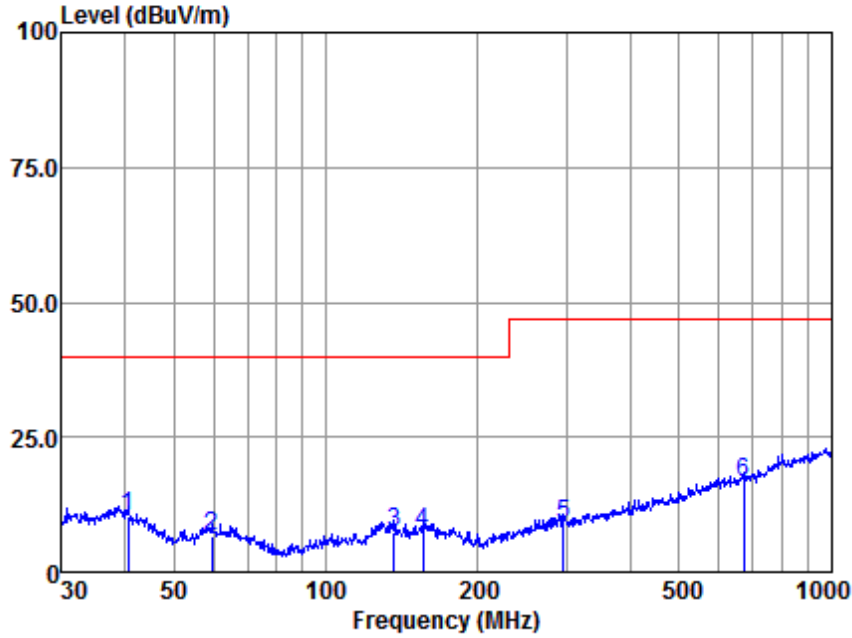

Antenna Polarity :HORIZONTAL
EUT/Project :1704TX
Test mode :e

| | Freq | Read Level | Antenna Factor | Cable Loss | Preamp Factor | Emission Level | Limit Line | Over Limit | Remark |
|---|--------|------------|----------------|------------|---------------|----------------|------------|------------|--------|
| | MHz | dBuv | dB/m | dB | dB | dBuv/m | dBuv/m | dB | |
| 1 | 40.56 | 36.13 | 15.94 | 0.79 | 42.62 | 10.24 | 40.00 | -29.76 | QP |
| 2 | 59.44 | 36.07 | 12.48 | 0.89 | 42.65 | 6.79 | 40.00 | -33.21 | QP |
| 3 | 136.46 | 37.79 | 11.80 | 0.60 | 42.64 | 7.55 | 40.00 | -32.45 | QP |
| 4 | 155.91 | 36.74 | 12.63 | 0.53 | 42.60 | 7.30 | 40.00 | -32.70 | QP |
| 5 | 295.15 | 37.51 | 13.04 | 0.65 | 42.41 | 8.79 | 47.00 | -38.21 | QP |
| 6 | 670.49 | 37.11 | 19.98 | 1.79 | 42.30 | 16.58 | 47.00 | -30.42 | QP |

Note:Emission Level=Read Level+Antenna Factor+Cable loss-Preamp Factor

Mode:e; Polarization:Vertical

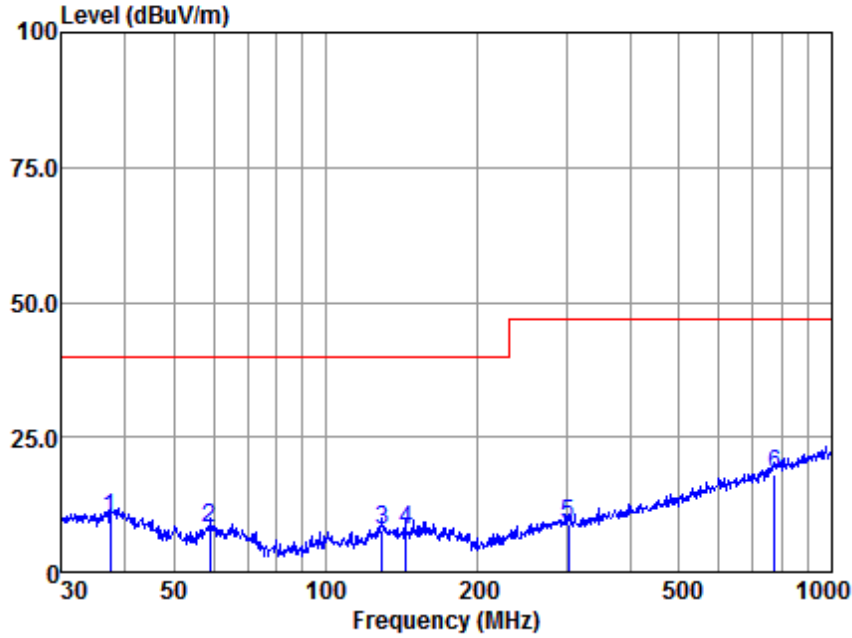

Antenna Polarity :VERTICAL
EUT/Project :1704TX
Test mode :e

| | Freq | Read Level | Antenna Factor | Cable Loss | Preamp Factor | Emission Level | Limit Line | Over Limit | Remark |
|---|--------|------------|----------------|------------|---------------|----------------|------------|------------|--------|
| | MHz | dBuv | dB/m | dB | dB | dBuv/m | dBuv/m | dB | |
| 1 | 37.42 | 35.76 | 16.07 | 0.74 | 42.62 | 9.95 | 40.00 | -30.05 | QP |
| 2 | 59.03 | 37.40 | 12.41 | 0.89 | 42.65 | 8.05 | 40.00 | -31.95 | QP |
| 3 | 129.01 | 37.37 | 12.56 | 0.64 | 42.66 | 7.91 | 40.00 | -32.09 | QP |
| 4 | 143.83 | 38.26 | 11.54 | 0.57 | 42.62 | 7.75 | 40.00 | -32.25 | QP |
| 5 | 301.42 | 37.20 | 13.22 | 0.67 | 42.40 | 8.69 | 47.00 | -38.31 | QP |
| 6 | 774.16 | 37.08 | 21.50 | 2.11 | 42.55 | 18.14 | 47.00 | -28.86 | QP |

Note:Emission Level=Read Level+Antenna Factor+Cable loss-Preamp Factor

6.3 Harmonic Current Emission

Test Requirement: EN 61000-6-3:2007 +A1:2011

Test Method: EN 61000-3-2:2014

Frequency Range: 100Hz to 2kHz

There is no need for Harmonics test to be performed on this product (rated power is less than 75W) in accordance with EN 61000-3-2:2014.

For further details, please refer to Clause 7 of EN 61000-3-2 which states:

"For the following categories of equipment, limits are not specified in this standard.- equipment with a rated power of 75W or less, other than lighting equipment."

6.4 Voltage Fluctuations and Flicker

Test Requirement: EN 61000-6-3:2007 +A1:2011
Test Method: EN 61000-3-3:2013

6.4.1 E.U.T. Operation

Operating Environment:

Temperature: 22 °C Humidity: 50 % RH Atmospheric Pressure: 1020 mbar

Test mode:
a: Keep mode CDB116A running with AC220V,
b: Keep mode CDB116E running with AC24V,
c: Keep mode CDB116B running with DC24V,
d: Keep mode CDB116F running with DC12V,
e: Keep mode CDB116C running with AC110V.

6.4.2 Test Setup Diagram

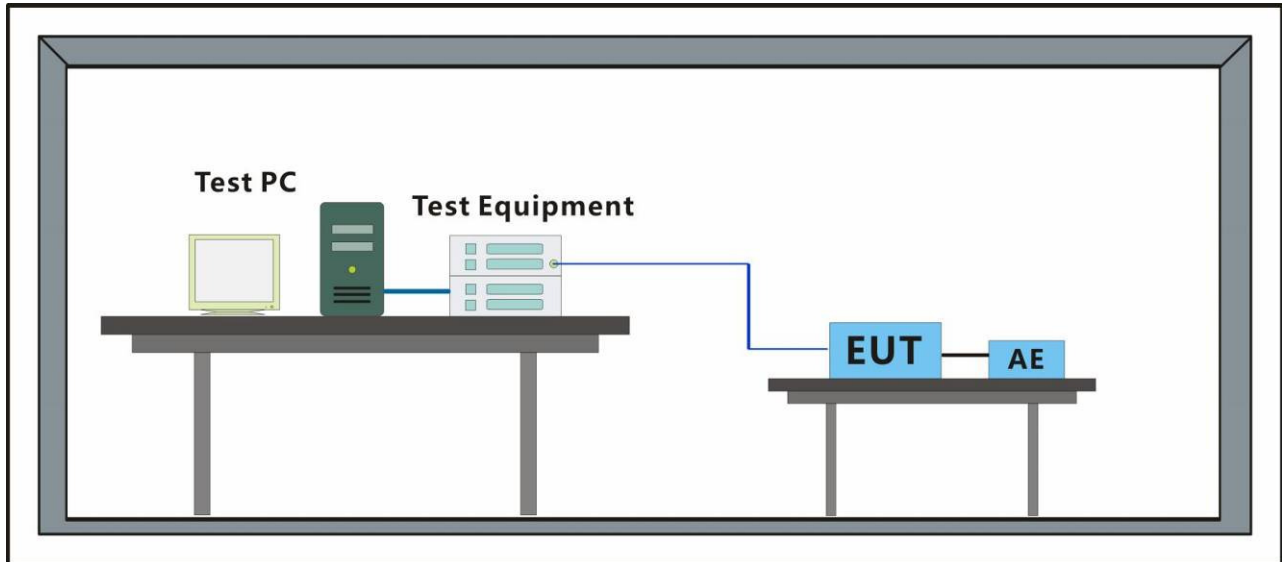

6.4.3 Measurement Data

Mode:a

| | | | | |
|---------------------------------|--------|------------------|-------|------|
| Vrms at the end of test (Volt): | 229.94 | | | |
| T-max (mS): | 0 | Test limit (mS): | 500.0 | Pass |
| Highest dc (%): | 0.55 | Test limit (%): | 3.30 | Pass |
| Highest dmax (%): | 1.64 | Test limit (%): | 4.00 | Pass |
| Highest Pst (10 min. period): | 0.157 | Test limit: | 1.000 | Pass |
| Highest Plt (2 hr. period): | 0.108 | Test limit: | 0.650 | Pass |

Mode:b

| | | | | |
|---------------------------------|--------|------------------|-------|------|
| Vrms at the end of test (Volt): | 242.94 | | | |
| T-max (mS): | 0 | Test limit (mS): | 500.0 | Pass |
| Highest dc (%): | 2.15 | Test limit (%): | 3.30 | Pass |
| Highest dmax (%): | 0.14 | Test limit (%): | 4.00 | Pass |
| Highest Pst (10 min. period): | 0.327 | Test limit: | 1.000 | Pass |
| Highest Plt (2 hr. period): | 0.518 | Test limit: | 0.650 | Pass |



Mode:c

| | | | | |
|---------------------------------|--------|------------------|-------|------|
| Vrms at the end of test (Volt): | 242.74 | | | |
| T-max (mS): | 0 | Test limit (mS): | 500.0 | Pass |
| Highest dc (%): | 0.45 | Test limit (%): | 3.30 | Pass |
| Highest dmax (%): | 1.66 | Test limit (%): | 4.00 | Pass |
| Highest Pst (10 min. period): | 0.297 | Test limit: | 1.000 | Pass |
| Highest Plt (2 hr. period): | 0.3 68 | Test limit: | 0.650 | Pass |

Mode:d

| | | | | |
|---------------------------------|--------|------------------|-------|------|
| Vrms at the end of test (Volt): | 232.74 | | | |
| T-max (mS): | 0 | Test limit (mS): | 500.0 | Pass |
| Highest dc (%): | 0.45 | Test limit (%): | 3.30 | Pass |
| Highest dmax (%): | 0.41 | Test limit (%): | 4.00 | Pass |
| Highest Pst (10 min. period): | 0.857 | Test limit: | 1.000 | Pass |
| Highest Plt (2 hr. period): | 0.272 | Test limit: | 0.650 | Pass |

Mode:e

| | | | | |
|---------------------------------|--------|------------------|-------|------|
| Vrms at the end of test (Volt): | 111.74 | | | |
| T-max (mS): | 0 | Test limit (mS): | 500.0 | Pass |
| Highest dc (%): | 0.23 | Test limit (%): | 3.30 | Pass |
| Highest dmax (%): | 0.36 | Test limit (%): | 4.00 | Pass |
| Highest Pst (10 min. period): | 0.13 | Test limit: | 1.000 | Pass |
| Highest Plt (2 hr. period): | 0.292 | Test limit: | 0.650 | Pass |

7 Immunity Test Results

7.1 Performance Criteria Description in EN 61000-6-1:2007

- Criterion A** The apparatus shall continue to operate as intended during and after the test. No degradation of performance or loss of function is allowed below a performance level specified by the manufacturer, when the apparatus is used as intended. The performance level may be replaced by a permissible loss of performance. If the minimum performance level or the permissible performance loss is not specified by the manufacturer, either of these may be derived from the product description and documentation and what the user may reasonably expect from the apparatus if used as intended.
- Criterion B** The apparatus shall continue to operate as intended after the test. No degradation of performance or loss of function is allowed below a performance level specified by the manufacturer, when the apparatus is used as intended. The performance level may be replaced by a permissible loss of performance. During the test, degradation of performance is however allowed. No change of actual operating state or stored data is allowed. If the minimum performance level or the permissible performance loss is not specified by the manufacturer, either of these may be derived from the product description and documentation and what the user may reasonably expect from the apparatus if used as intended.
- Criterion C** Temporary loss of function is allowed, provided the function is self-recoverable or can be restored by the operation of the controls.

7.2 Electrostatic Discharge

Test Requirement: EN 61000-6-1:2007
 Test Method: EN 61000-4-2:2009
 Performance Criterion: B
 Discharge Impedance: 330Ω/150pF
 Number of Discharge: Minimum 10 times at each test point
 Discharge Mode: Single Discharge
 Discharge Period: 1 second minimum

7.2.1 Test Setup Diagram

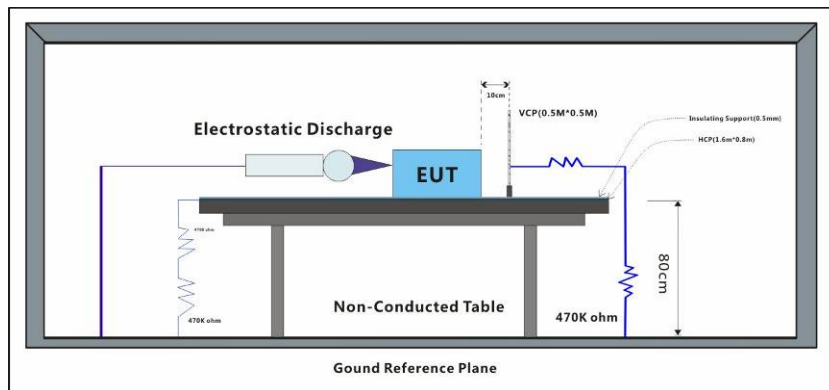

7.2.2 E.U.T. Operation

Operating Environment:

Temperature: 22 °C Humidity: 50 % RH Atmospheric Pressure: 1002 mbar

Test mode:
 a: Keep mode CDB116A running with AC220V,
 b: Keep mode CDB116E running with AC24V,
 c: Keep mode CDB116B running with DC24V,
 d: Keep mode CDB116F running with DC12V,
 e: Keep mode CDB116C running with AC110V.

7.2.3 Test Results:

Observations: Test Point:

1. All insulated enclosure and seams.
2. All accessible metal parts of the enclosure.
3. All side

| Discharge type | Level (kV) | Polarity | Test Point | Result / Observations |
|---------------------|------------|----------|------------|-----------------------|
| Air Discharge | 2,4,8 | + | 1 | A |
| Air Discharge | 2,4,8 | - | 1 | A |
| Contact Discharge | 4 | + | 2 | A |
| Contact Discharge | 4 | - | 2 | A |
| Horizontal Coupling | 4 | + | 3 | A |
| Horizontal Coupling | 4 | - | 3 | A |
| Vertical Coupling | 4 | + | 3 | A |
| Vertical Coupling | 4 | - | 3 | A |

Results:

A: No degradation in the performance of the EUT was observed.

7.3 Radiated Immunity(80MHz-2.7GHz)

Test Requirement: EN 61000-6-1:2007
 Test Method: EN 61000-4-3:2006 +A1:2008+A2:2010
 Performance Criterion: A
 Frequency Range: 80MHz to 1GHz, 1.4GHz to 2GHz, 2GHz to 2.7GHz
 Antenna Polarisation: Vertical and Horizontal
 Modulation: 1kHz,80% Amp. Mod,1% increment

7.3.1 Test Setup Diagram

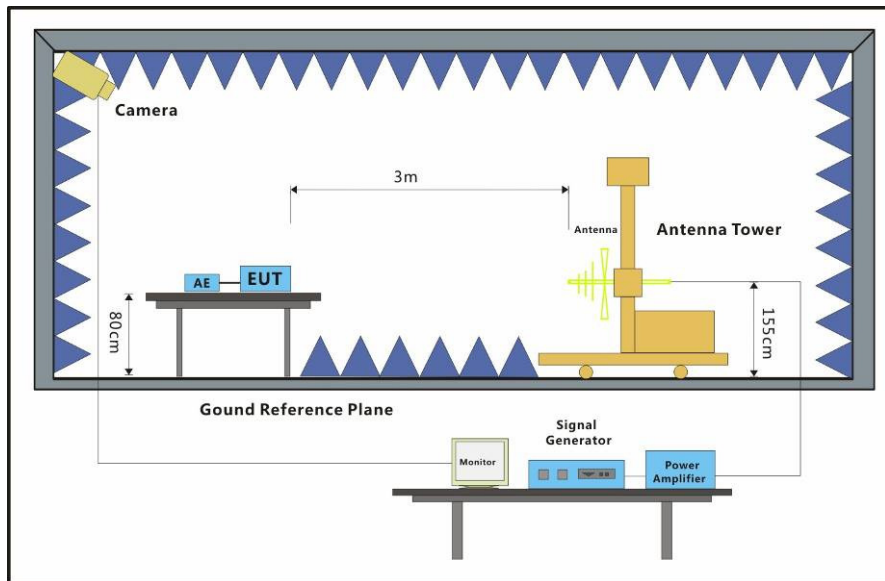

7.3.2 E.U.T. Operation

Operating Environment:
 Temperature: 22 °C Humidity: 50 % RH Atmospheric Pressure: 1020 mbar
 Test mode:
 a: Keep mode CDB116A running with AC220V,
 b: Keep mode CDB116E running with AC24V,
 c: Keep mode CDB116B running with DC24V,
 d: Keep mode CDB116F running with DC12V,
 e: Keep mode CDB116C running with AC110V.

7.3.3 Test Results:

| Frequency | Level (V/m) | EUT Face | Dwell time | Result / Observations |
|-------------|-------------|-----------|------------|-----------------------|
| 80MHz-1GHz | 3 | Front | 2s | A |
| 80MHz-1GHz | 3 | Back | 2s | A |
| 80MHz-1GHz | 3 | Left | 2s | A |
| 80MHz-1GHz | 3 | Right | 2s | A |
| 80MHz-1GHz | 3 | Top | 2s | A |
| 80MHz-1GHz | 3 | Underside | 2s | A |
| 1.4GHz-2GHz | 3 | Front | 2s | A |
| 1.4GHz-2GHz | 3 | Back | 2s | A |
| 1.4GHz-2GHz | 3 | Left | 2s | A |
| 1.4GHz-2GHz | 3 | Right | 2s | A |
| 1.4GHz-2GHz | 3 | Top | 2s | A |
| 1.4GHz-2GHz | 3 | Underside | 2s | A |



| | | | | |
|-------------|---|-----------|----|---|
| 2GHz-2.7GHz | 1 | Front | 2s | A |
| 2GHz-2.7GHz | 1 | Back | 2s | A |
| 2GHz-2.7GHz | 1 | Left | 2s | A |
| 2GHz-2.7GHz | 1 | Right | 2s | A |
| 2GHz-2.7GHz | 1 | Top | 2s | A |
| 2GHz-2.7GHz | 1 | Underside | 2s | A |

Results:

A: No degradation in the performance of the EUT was observed.

7.4 Electrical Fast Transients/Burst at Power Port

Test Requirement: EN 61000-6-1:2007
 Test Method: EN 61000-4-4:2012
 Performance Criterion: B
 Repetition Frequency: 5kHz
 Burst Period: 300ms
 Test Duration: 2 minute per level & polarity

7.4.1 Test Setup Diagram

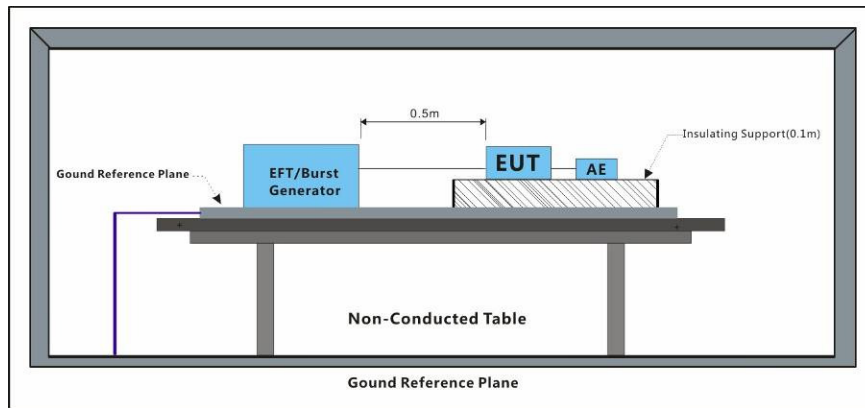

7.4.2 E.U.T. Operation

Operating Environment:
 Temperature: 22 °C Humidity: 50 % RH Atmospheric Pressure: 1002 mbar
 Test mode:
 a: Keep mode CDB116A running with AC220V,
 b: Keep mode CDB116E running with AC24V,
 c: Keep mode CDB116B running with DC24V,
 d: Keep mode CDB116F running with DC12V,
 e: Keep mode CDB116C running with AC110V.

7.4.3 Test Results:

| Test Line | Level (kV) | Polarity | CDN/Clamp | Result / Observations |
|---------------|------------|----------|-----------|-----------------------|
| AC power port | 1 | + | CDN | A |
| AC power port | 1 | - | CDN | A |

Results:

A: No degradation in the performance of the EUT was observed.

7.5 Surge at Power Port

Test Requirement: EN 61000-6-1:2007
 Test Method: EN 61000-4-5:2014 +A1:2017
 Performance Criterion: B
 Interval: 60s between each surge
 No. of surges: 5 positive, 5 negative at 0°, 90°, 180°, 270°.

7.5.1 Test Setup Diagram

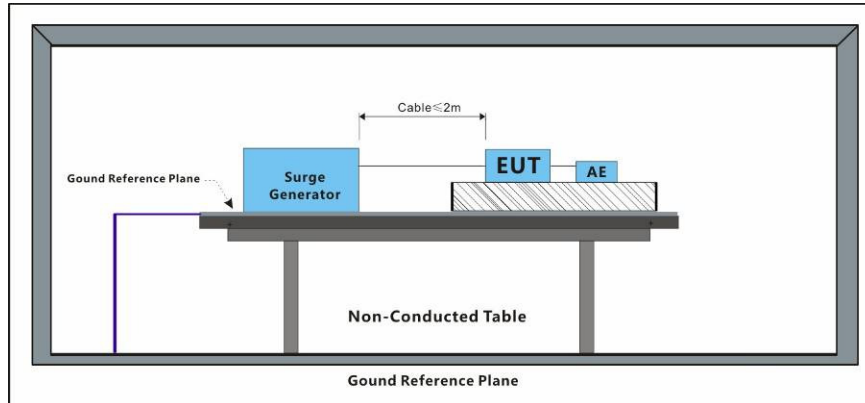

7.5.2 E.U.T. Operation

Operating Environment:
 Temperature: 22 °C Humidity: 50 % RH Atmospheric Pressure: 1002 mbar
 Test mode:
 a: Keep mode CDB116A running with AC220V,
 b: Keep mode CDB116E running with AC24V,
 c: Keep mode CDB116B running with DC24V,
 d: Keep mode CDB116F running with DC12V,
 e: Keep mode CDB116C running with AC110V.

7.5.3 Test Results:

| Test Line | Level (kV) | Polarity | Phase (deg) | Result / Observations |
|-----------|------------|----------|-------------|-----------------------|
| L-N | 1 | + | 0° | A |
| L-N | 1 | - | 0° | A |
| L-N | 1 | + | 90° | A |
| L-N | 1 | - | 90° | A |
| L-N | 1 | + | 180° | A |
| L-N | 1 | - | 180° | A |
| L-N | 1 | + | 270° | A |
| L-N | 1 | - | 270° | A |
| L-PE | 2 | + | 0° | A |
| L-PE | 2 | - | 0° | A |
| L-PE | 2 | + | 90° | A |
| L-PE | 2 | - | 90° | A |
| L-PE | 2 | + | 180° | A |
| L-PE | 2 | - | 180° | A |
| L-PE | 2 | + | 270° | A |
| L-PE | 2 | - | 270° | A |
| N-PE | 2 | + | 0° | A |
| N-PE | 2 | - | 0° | A |



| | | | | |
|------|---|---|------|---|
| N-PE | 2 | + | 90° | A |
| N-PE | 2 | - | 90° | A |
| N-PE | 2 | + | 180° | A |
| N-PE | 2 | - | 180° | A |
| N-PE | 2 | + | 270° | A |
| N-PE | 2 | - | 270° | A |

Results:

A: No degradation in the performance of the EUT was observed.

7.6 Conducted Immunity at Power Port (150kHz-80MHz)

Test Requirement: EN 61000-6-1:2007
 Test Method: EN 61000-4-6:2014
 Performance Criterion: A
 Frequency Range: 0.15MHz to 80MHz
 Modulation: 80%, 1kHz Amplitude Modulation
 Step Size: 1%

7.6.1 Test Setup Diagram

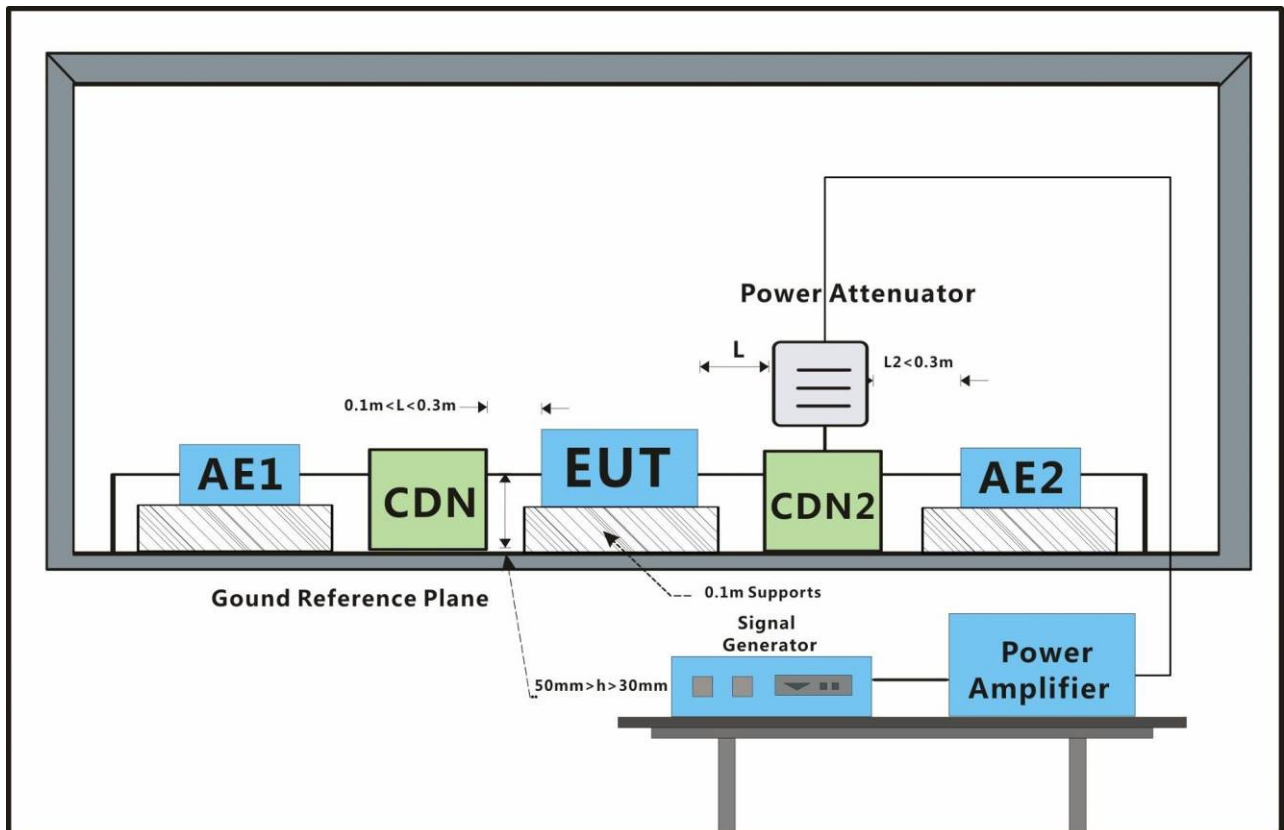

7.6.2 E.U.T. Operation

Operating Environment:

Temperature: 22 °C Humidity: 50 % RH Atmospheric Pressure: 1002 mbar

Test mode:
 a: Keep mode CDB116A running with AC220V,
 b: Keep mode CDB116E running with AC24V,
 c: Keep mode CDB116B running with DC24V,
 d: Keep mode CDB116F running with DC12V,
 e: Keep mode CDB116C running with AC110V.

7.6.3 Test Results:

| Cable port | Level (Vrms) | CDN/Clamp | Dwell time | Result / Observations |
|---------------|--------------|-----------|------------|-----------------------|
| AC power port | 3 | CDN | 2s | A |

Results:

A: No degradation in the performance of the EUT was observed.

7.7 Power Frequency Magnetic Field

Test Requirement: EN 61000-6-1:2007
Test Method: EN 61000-4-8:2010
Performance Criterion: A

7.7.1 Test Setup Diagram

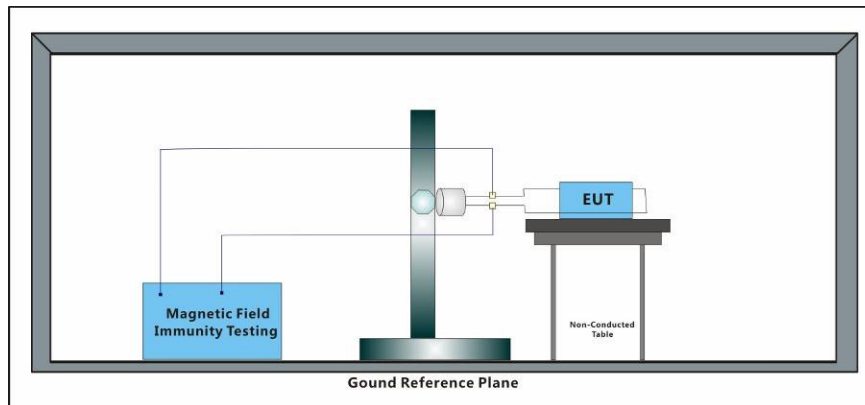

7.7.2 E.U.T. Operation

Operating Environment:

Temperature: 22 °C Humidity: 50 % RH Atmospheric Pressure: 1002 mbar

Test mode:
a: Keep mode CDB116A running with AC220V,
b: Keep mode CDB116E running with AC24V,
c: Keep mode CDB116B running with DC24V,
d: Keep mode CDB116F running with DC12V,
e: Keep mode CDB116C running with AC110V.

7.7.3 Test Results:

| Frequency | Level (A/m) | Axial | Magnetic Field Type | Result / Observations |
|-----------|-------------|-------|---------------------|-----------------------|
| 50Hz | 3 | X | Continuous filed | A |
| 50Hz | 3 | Y | Continuous filed | A |
| 50Hz | 3 | Z | Continuous filed | A |

Results:

A: No degradation in the performance of the EUT was observed.

7.8 Voltage Dips and Interruptions

Test Requirement: EN 61000-6-1:2007
 Test Method: EN 61000-4-11:2004 +A1:2017
 Performance Criterion: 0% of UT (Supply Voltage) for 0.5 Periods:B; 0% of UT for 1 Periods:B; 0% of UT for 250 Periods:C; 70% of UT for 25 Periods:C;
 No. of Dips / Interruptions: 3 per Level
 Time between dropout 10s

7.8.1 Test Setup Diagram

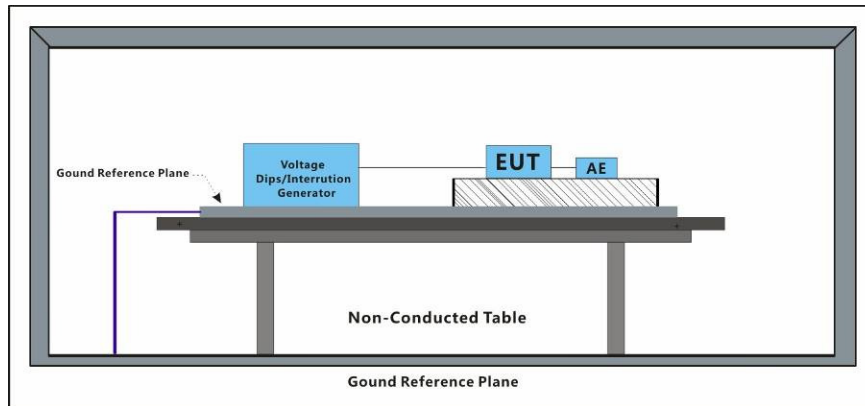

7.8.2 E.U.T. Operation

Operating Environment:
 Temperature: 22 °C Humidity: 50 % RH Atmospheric Pressure: 1002 mbar
 Test mode:
 a: Keep mode CDB116A running with AC220V,
 b: Keep mode CDB116E running with AC24V,
 c: Keep mode CDB116B running with DC24V,
 d: Keep mode CDB116F running with DC12V,
 e: Keep mode CDB116C running with AC110V.

7.8.3 Test Results:

| Level % UT | Phase (deg) | Duration | No. of Dips / Interruptions | Result / Observations |
|------------|-------------|------------|-----------------------------|-----------------------|
| 0 | 0° | 0.5 Cycles | 3 | A |
| 0 | 180° | 0.5 Cycles | 3 | A |
| 0 | 0° | 1 Cycles | 3 | A |
| 0 | 180° | 1 Cycles | 3 | A |
| 70 | 0° | 25 Cycles | 3 | A |
| 70 | 180° | 25 Cycles | 3 | A |
| 0 | 0° | 250 Cycles | 3 | B |
| 0 | 180° | 250 Cycles | 3 | B |

Results:

A: No degradation in the performance of the EUT was observed.
 B: During test, EUT stop work, After test ,the EUT restart automatically

8 Photographs

8.1 Conducted Emissions at Mains Terminals (150kHz-30MHz) Test Setup







8.2 Radiated Emissions (30MHz-1GHz) Test Setup







8.3 Voltage Fluctuations and Flicker Test Setup

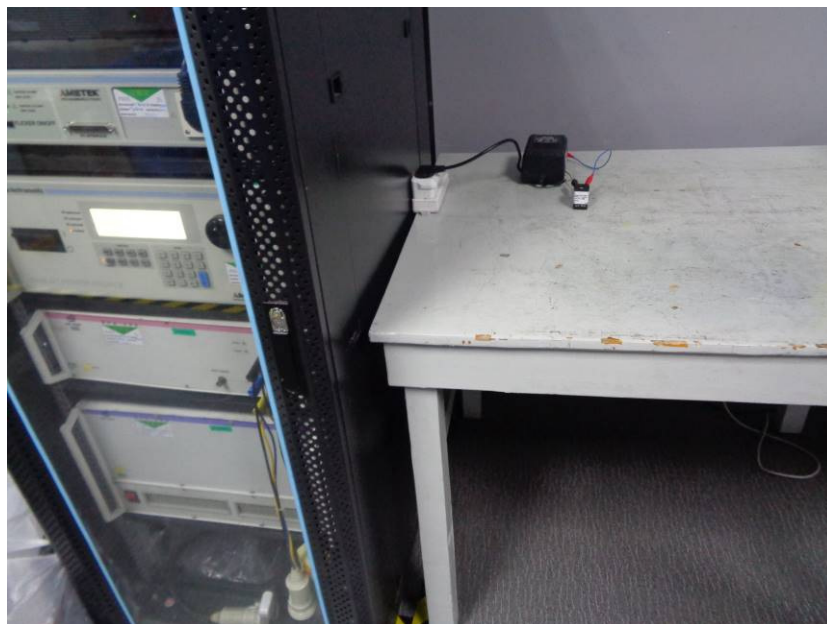

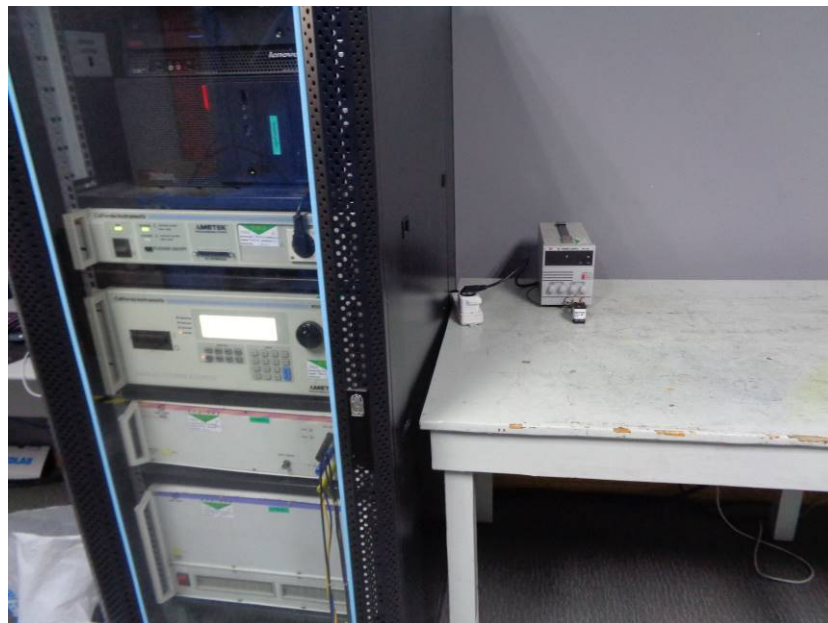



8.4 Electrostatic Discharge Test Setup







8.5 Radiated Immunity(80MHz-2.7GHz) Test Setup







8.6 Electrical Fast Transients/Burst at Power Port Test Setup



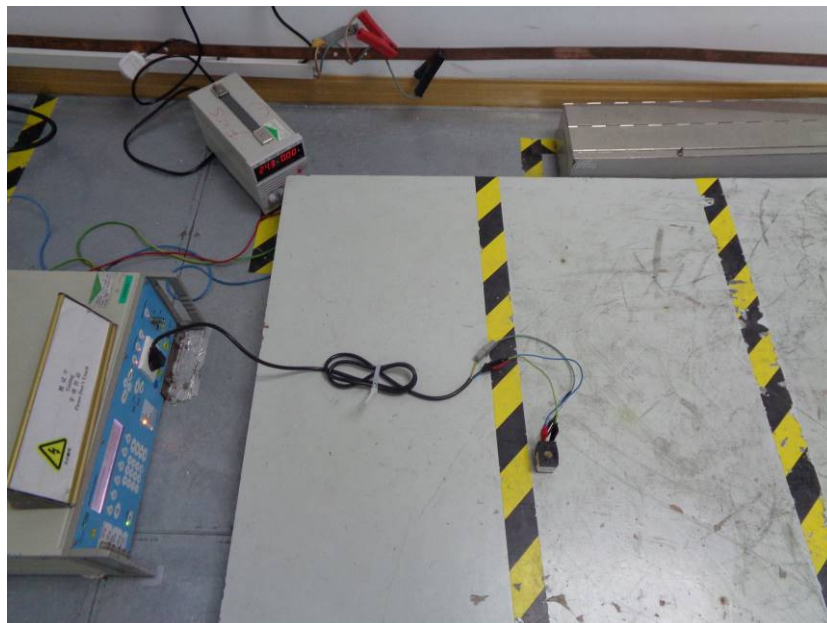

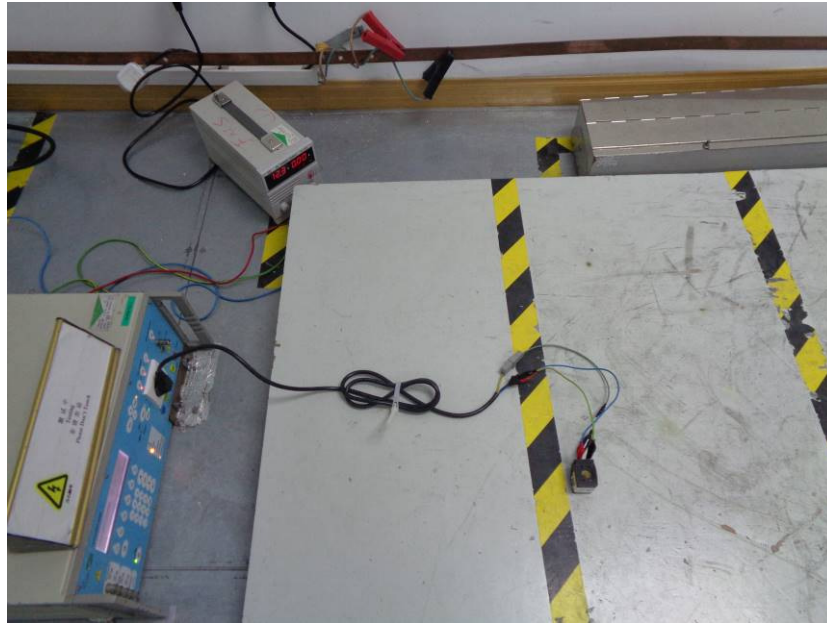

8.7 Surge at Power Port Test Setup



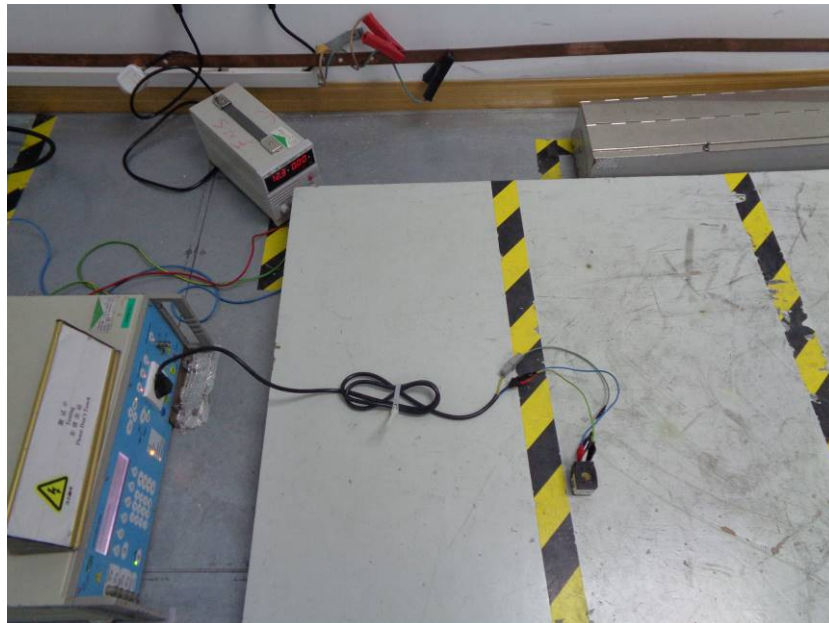



8.8 Conducted Immunity at Power Port (150kHz-80MHz) Test Setup

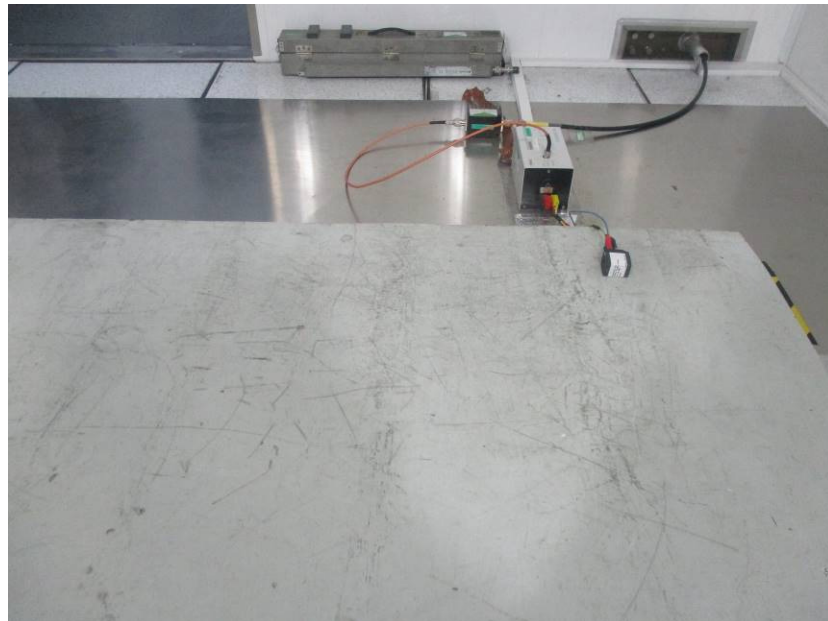

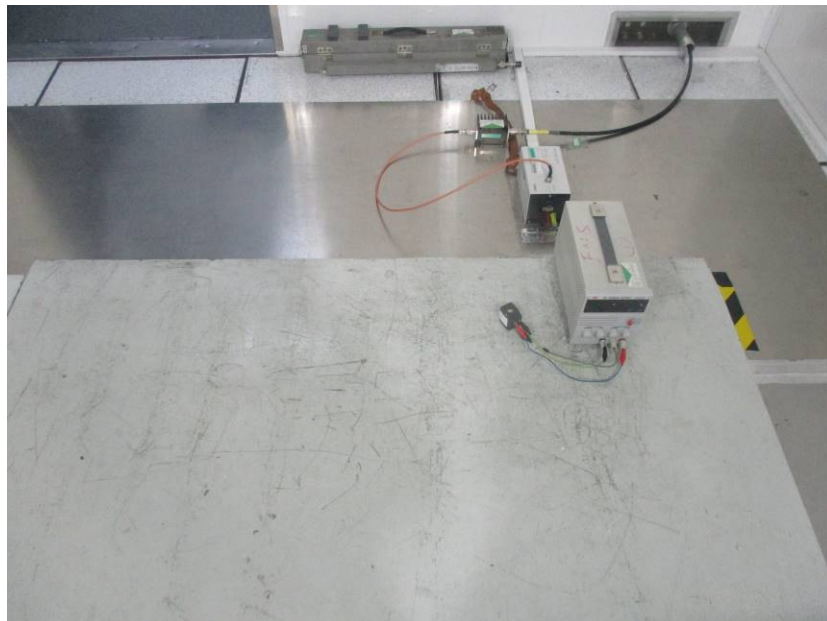
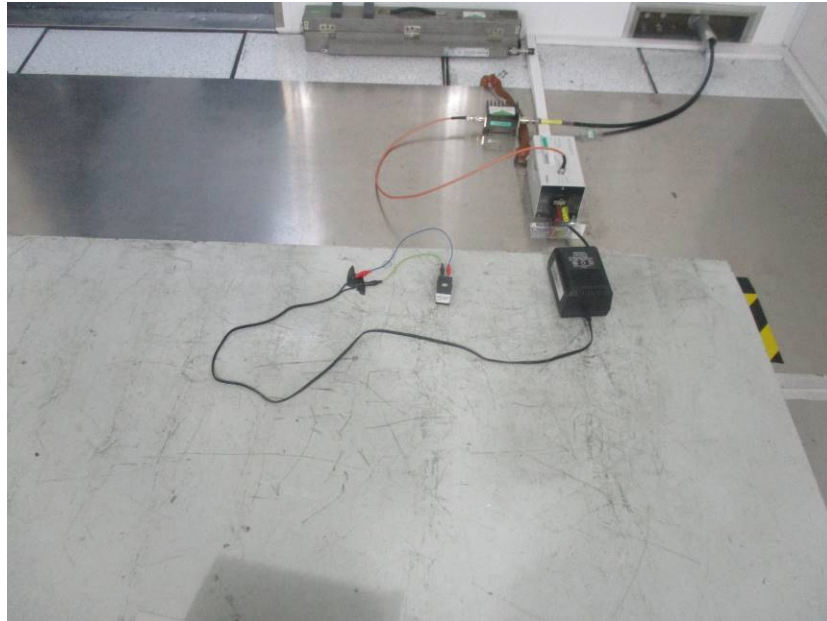

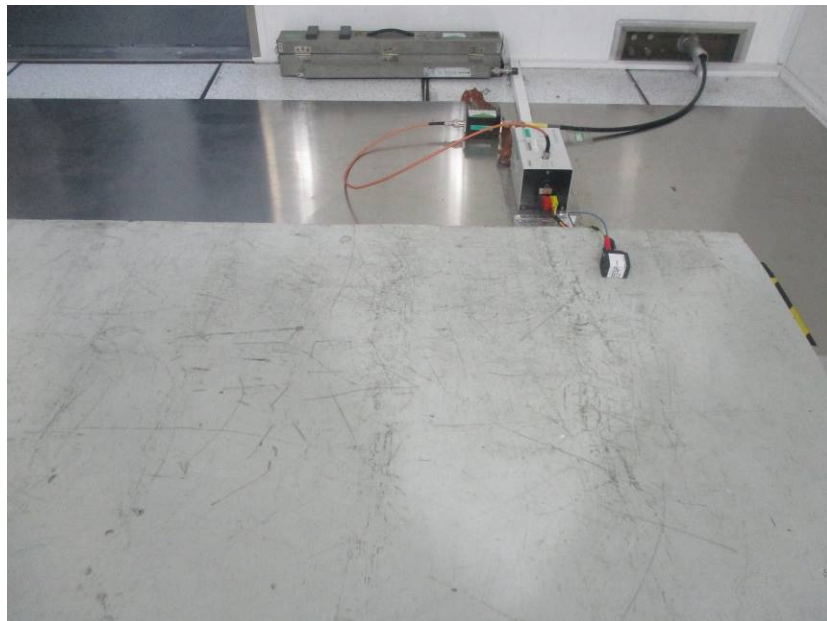
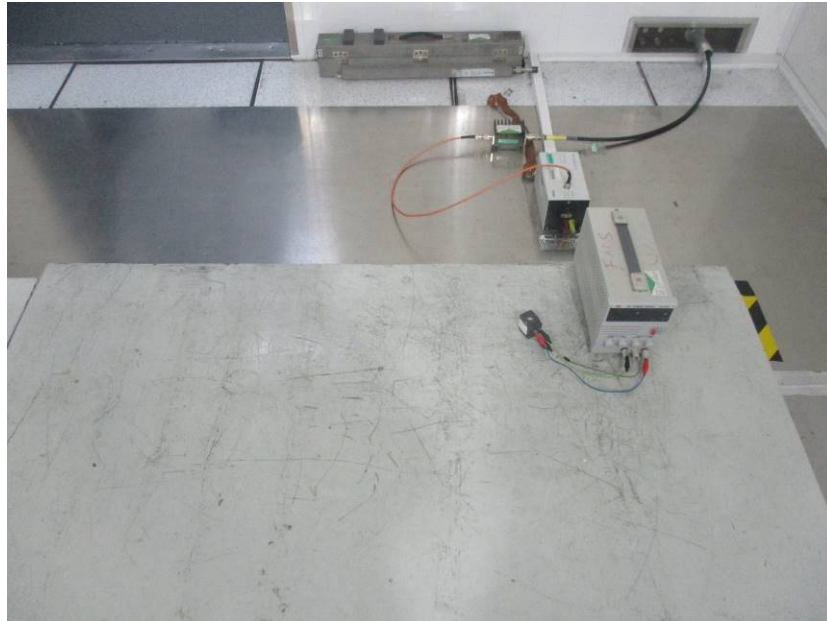

8.9 Power Frequency Magnetic Field Test Setup

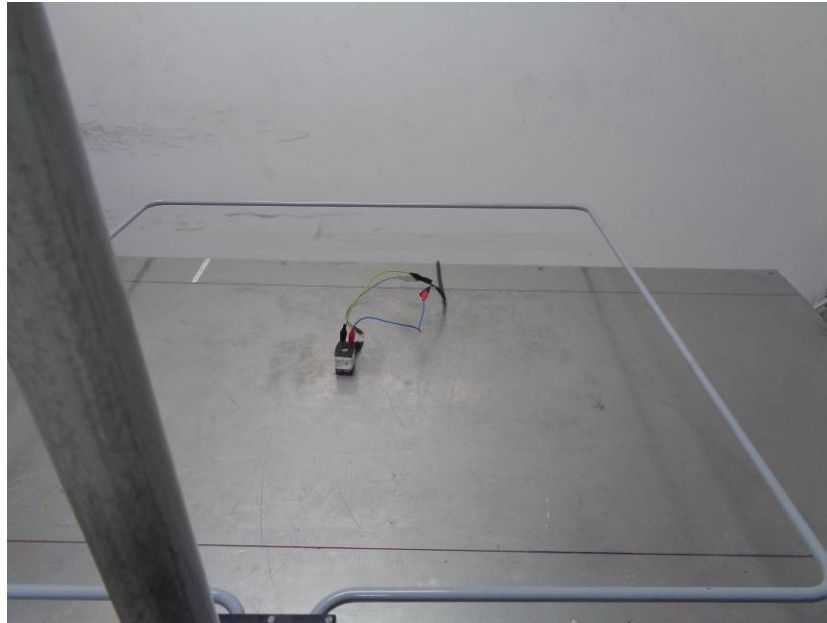

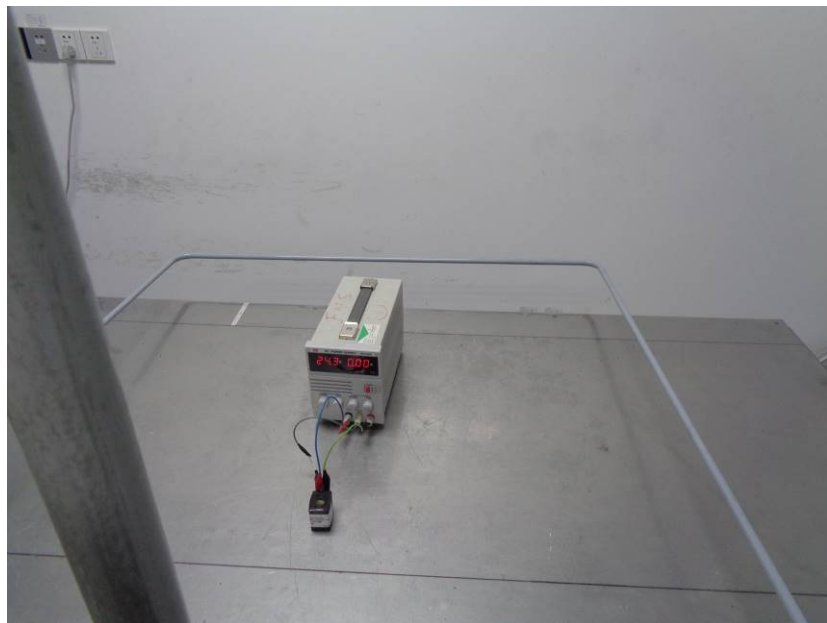
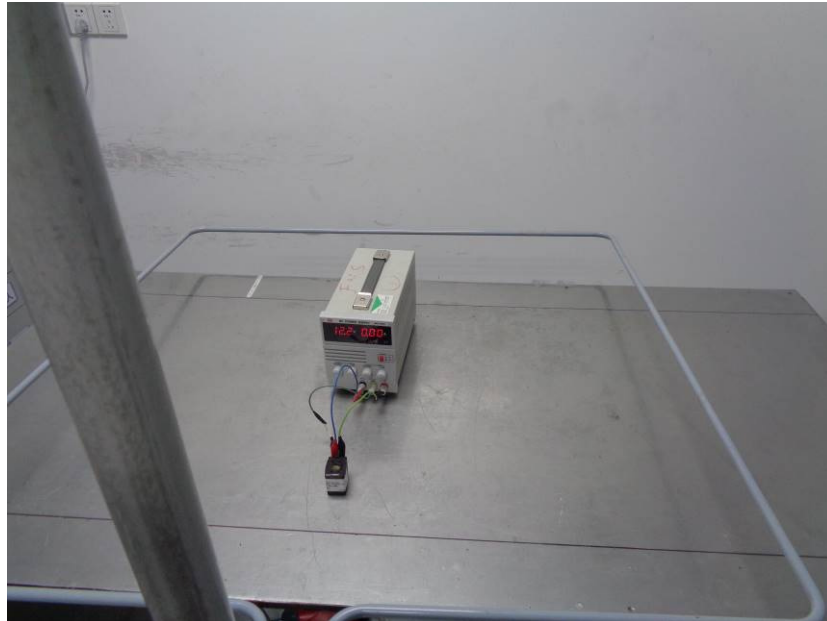



8.10 Voltage Dips and Interruptions Test Setup



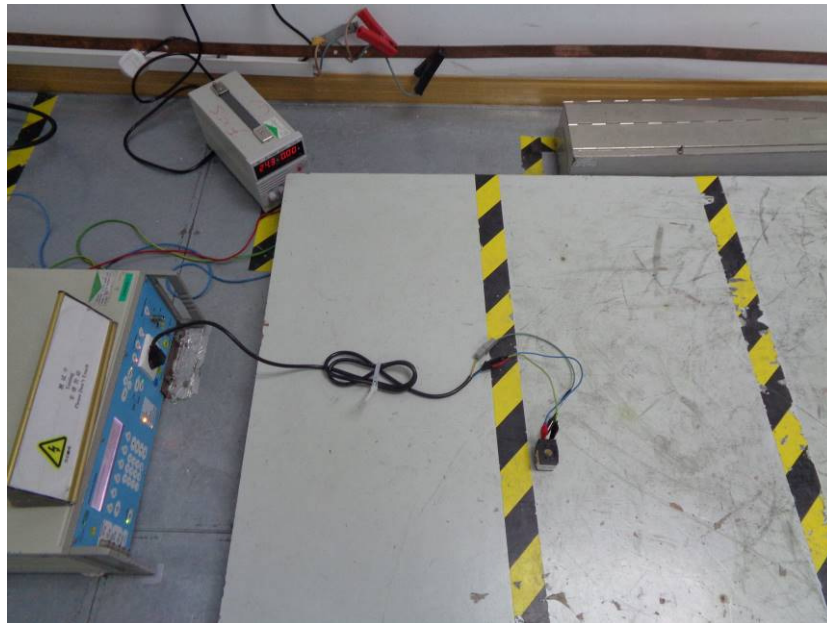

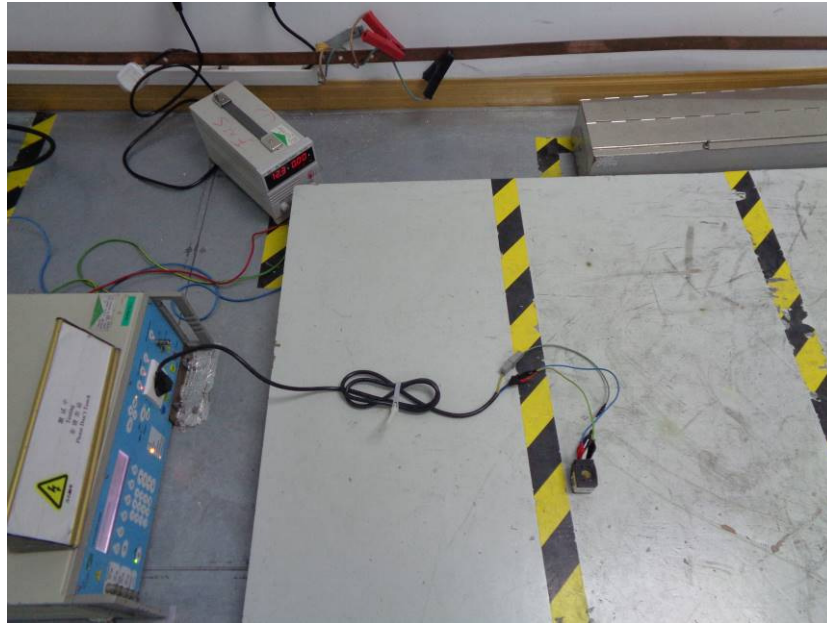

8.11 EUT Constructional Details (EUT Photos)



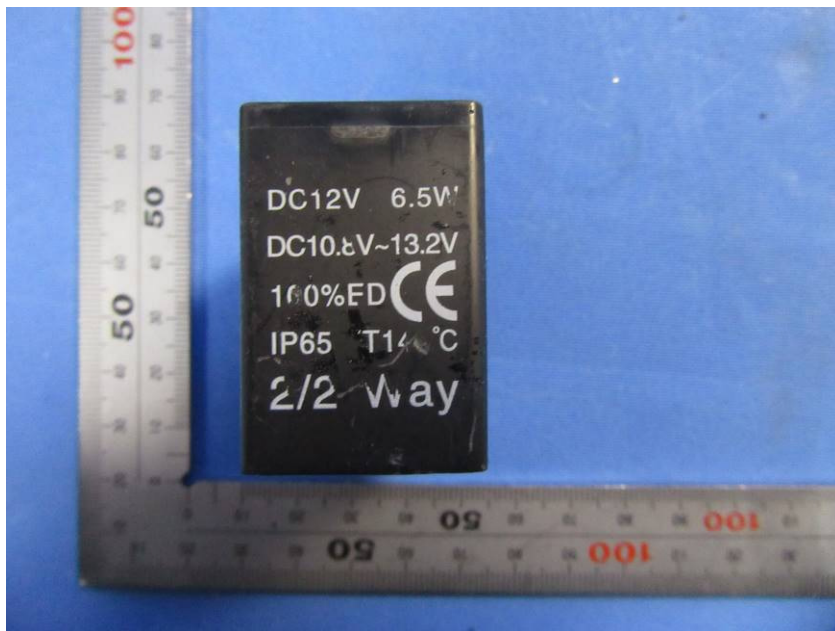
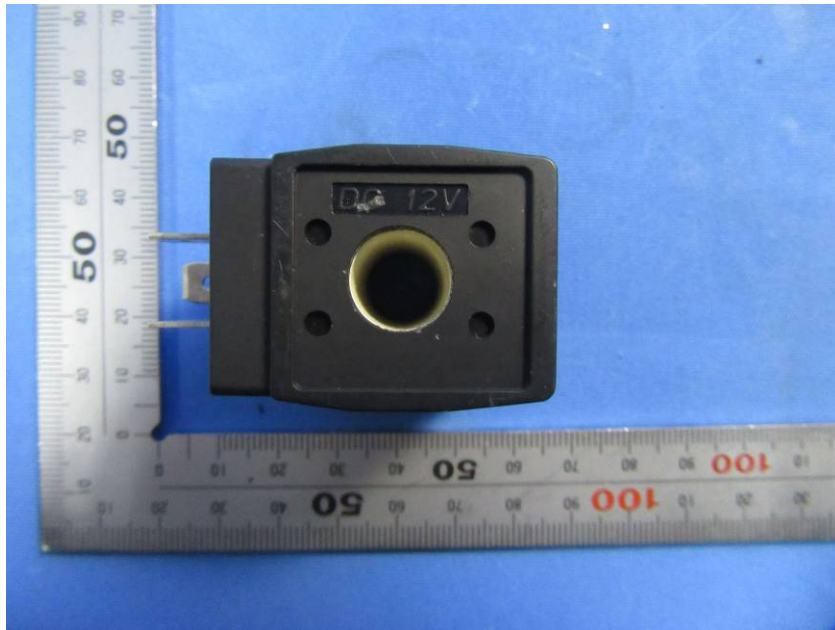

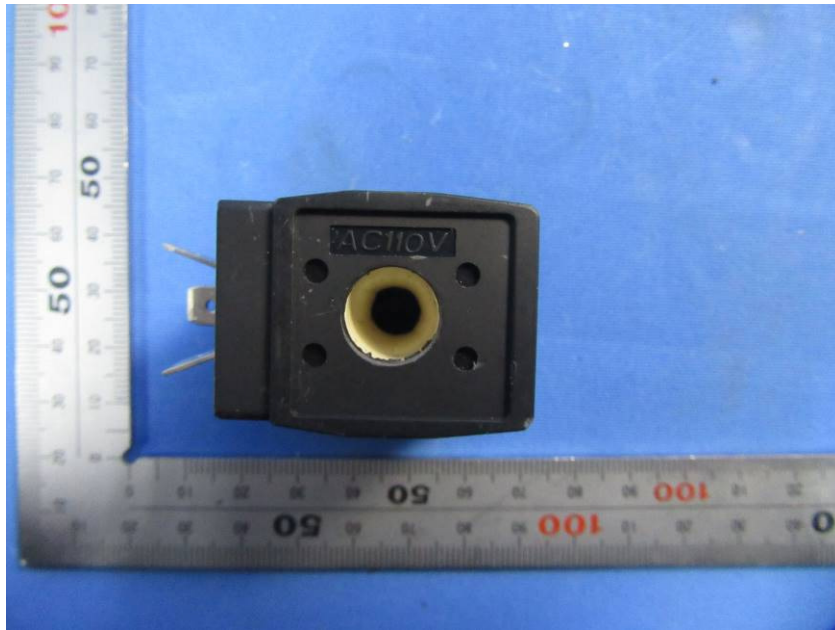

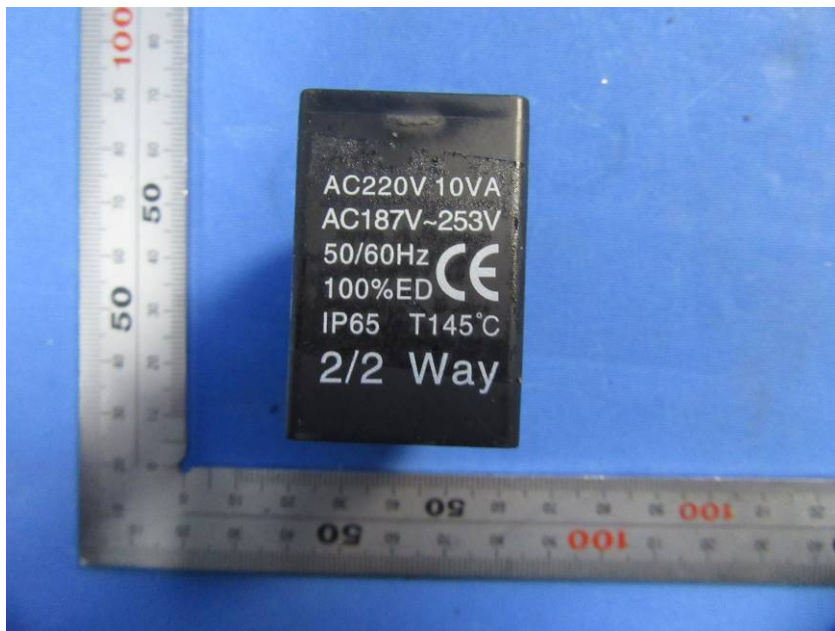
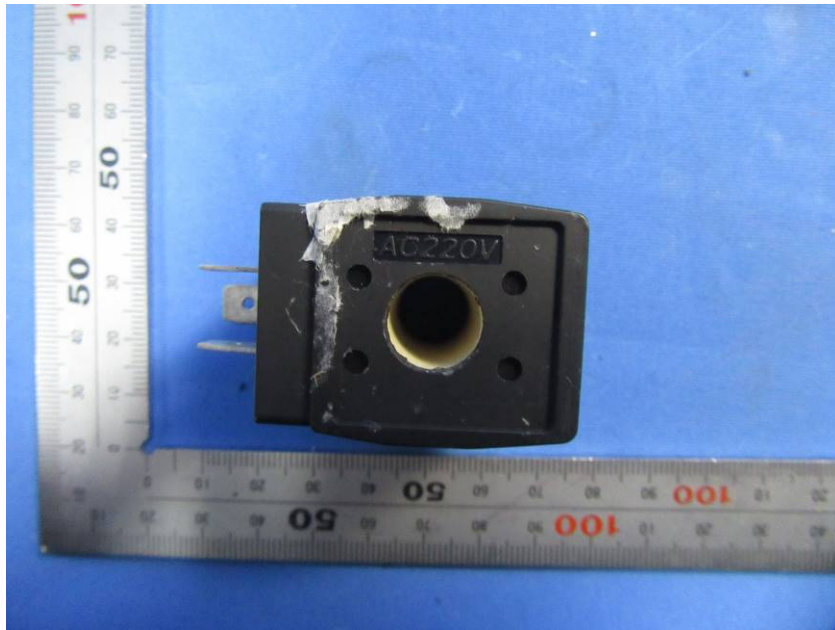

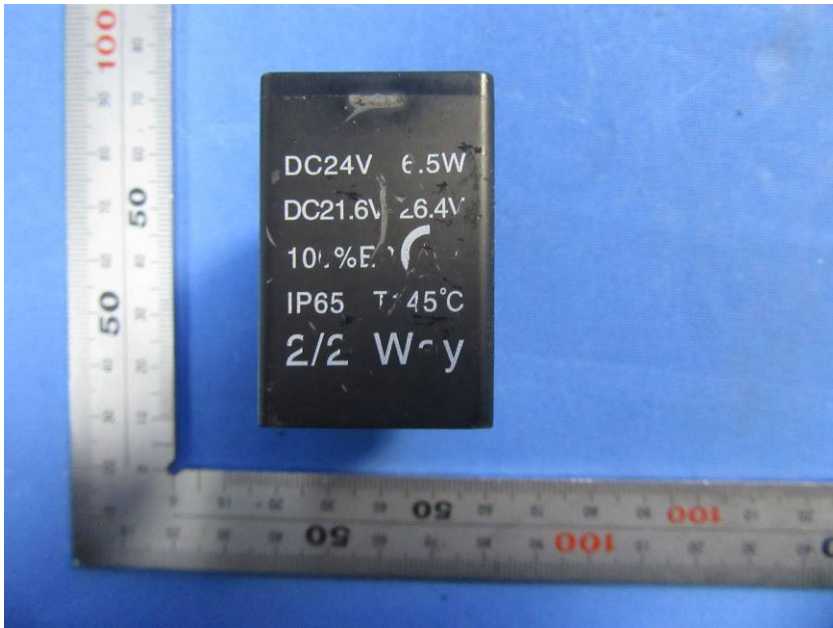

- End of the Report -